

**Model
K752**

Bulletin 283

Digital Draw and Extension Monitor



- Accuracy to 0.01%
- Designed for Paper, Plastics, Metals
- Economical Installation
- Reliable Mill Duty Components
- Target and Alarm Features

Description

The Model K752 is a microprocessor-based, digital draw and extension meter. It is designed to accept two frequency inputs, one from a high resolution rotary pulse generator like the Model M485, and one from a low resolution rotary pulse generator like the Model M185 UNIPULSER™.

The K752 can display draw and extension in either a Ratio or Percent Difference format ($\frac{A}{B}$ or $\frac{B-A}{A}$). The K752 can be configured to display several combinations of these variables, including length on cutoff control applications.

The K752 comes equipped with a serial link output that can be sent to a Remote Interface Module (RIM). The RIM can process the data and send it, along with date, time, event, and location, to a printer for permanent storage. The serial link output can also directly feed customer computers with RS422 serial link capability.

Multiple units can be tied in series to provide communication through a single port on customer computers.

Included as a standard with all K752 meters, are two programmable contact closure outputs, designed to notify operators and machines that the product is in/out of specification. (see figure D)

Applications

Extension Monitor

The basic design of the K752 allows two inputs to be measured and the calculated extension displayed on the digital readout. A typical application in the metals industry is tension leveling.

Data outputs from the K752 Serial Link can be processed by a RIM and sent to a printer to provide a hard copy extension profile of each coil/roll produced. (see figure A)

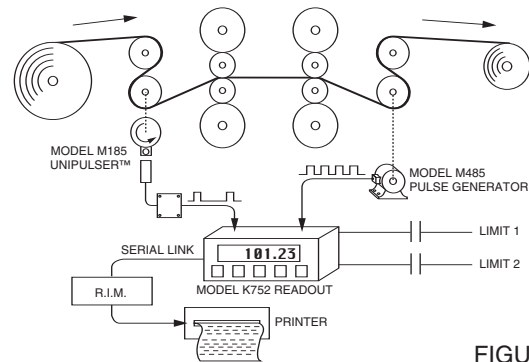

FIGURE A

Draw Monitor

The K752 is extremely useful in industries with web processes that are susceptible to overstretch and breakage. These conditions will result in either unsaleable product or machine downtime and the loss of production. By utilizing the K752 Draw and Extension Monitor, many of these downtime situations can be avoided.

In the paper industry, OPEN DRAWS are prime candidates for installation, as are extruder pull rolls in the plastics industry. This type of installation can be made in conjunction with existing indicating systems. (see figure B)

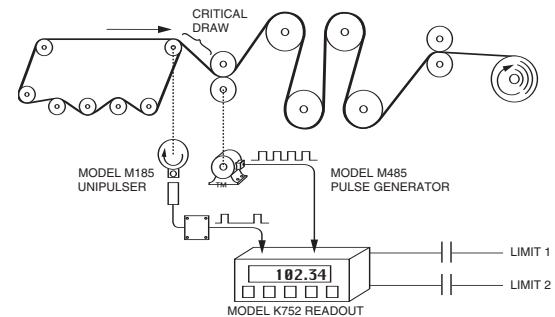

FIGURE B

Sheet Length Indicator

In certain industries, cut-to-length equipment is used to convert rolled material into sheets. The K752 can monitor cut lengths both with and without material in the machine. In many cases, the savings resulting from "set-ups without scrap" can pay for a K752 System in a matter of weeks.

The limit contact closures can be used to alarm and automatically reject material that is not within predetermined tolerances. (see figure C)

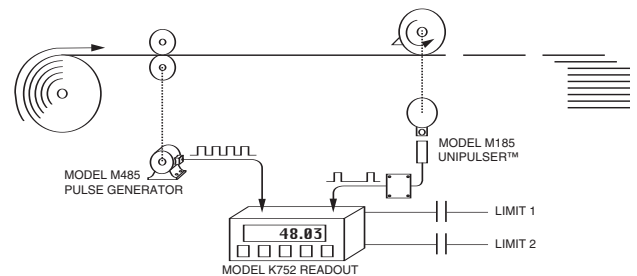

FIGURE C

Other Applications

- Line Shaft Clutch Slippage Monitor
- Speed Mismatch Detector
- Reel Spool Starter Monitor
- Dual Drum Rewinder Monitor
- Up to Speed Sensor



Limit Monitoring

The K752 is equipped with selectable limits which can provide contact closure outputs for improving process control. In the diagram below, the draw target has been established at 1.50. LIMIT 1 is set at 1.25 and 1.75, and LIMIT 2 is set at 1.00 and 2.00. LIMIT 2 represents an “out of specification” product.

The actual draw begins to increase and eventually exceeds LIMIT 1. A contact closure output notifies the operator that this out of limit condition exists. The opera-

tor responds by decreasing the draw to within LIMIT 1, thereby avoiding LIMIT 2 and the subsequent production of unsaleable product.

Conclusion

The K752 can save thousands of dollars by notifying operators of unacceptable conditions before the problems result in the loss of production and/or product.

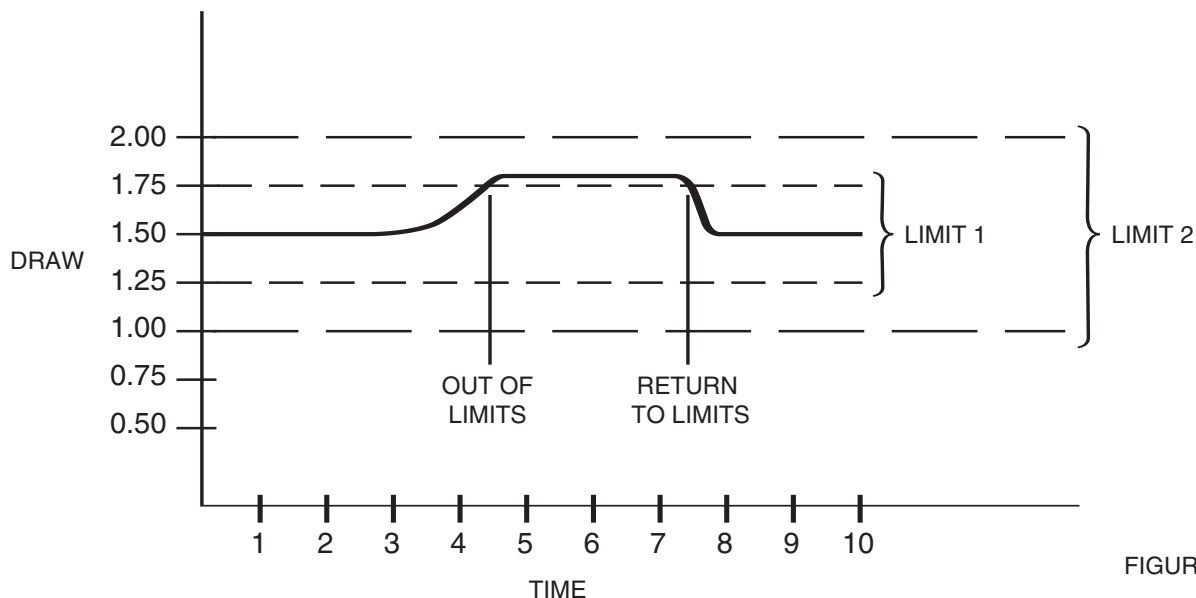

FIGURE D

Construction

The K752, like all Avtron products, is designed to operate in rugged mill environments where both temperature and humidity are high (see specifications for details).

Enclosures are gasketed, electronics protected, and every Avtron product is thermal cycled for 48 hours.

K752 Specifications

Operating Power: 115VAC, 50/60Hz, 0.25Amp Typical, 0.5Amp Max.

Operating Temperature: 32-140°F (0°- 60°C)

Operating Humidity: 5-95% RH

Signal Inputs: Two (2) single phase, zero-speed tachometer frequencies. Input circuit is transformer isolated. F2 should be 1 PPR. Inputs must meet the following restrictions.

	F1	F2
Min	75	0
Max	16000	100

or F1 > 16 F2

Operator Display: 6-digit, 0.8" memory display, with seven-segment characters.

Calibration: Compute and enter two calibration numbers or enter machine data for each. (Roll diameter, tach PPR, and gear ratio).

All calibration data is entered through a 5-key keyboard with range of 0.00001 to 999999. If power is lost, data is retained in memory.

Presets: Two (2) keyboard entered limits with full display range. Two Form C contacts on rear terminal block are programmed from the front panel for momentary or latched operation.

Serial Link: Two (2) standard modes of RS422 link:
Mode 0: Serial Link disabled.
Mode 1: Serial Link enabled-sends data down link (1) when a request is received over link,

(2) when the transfer or reset-transfer inputs on rear terminal block are activated, (3) at selected intervals, or (4) in response to limit activity.
Baud rate – Keyboard selectable, 110, 150, 300, 600, 1200, 2400, 4800, 9600, or 19,200 Baud.
Parity – Keyboard selectable, even, odd, none, mark, or space.

Control Inputs: **Reset** – High to low transition resets the unit.

Reset/Transfer – High to low transition sends the current data down the serial link and then resets the unit.

Transfer – High to low transition sends the current data down the serial link.

Hold – When low input, the display is frozen. Internal calculations are still performed.

Web Break/ Inhibit – When low input, the display and the internal counter are frozen.

Relay Reset – Resets tripped relays.

Lock Feature: Selected keyboard calibration functions can be locked out by connecting a jumper on the rear terminal block.

Installation: All connections are on two rows of 14 terminals on two blocks with 3/8" centers. All units are thermal cycled for 48 hours to ensure reliable operation. Potentially weak components are therefore eliminated prior to shipment.

Tach Supply: A +12 Volt, 250mA tach supply is available on rear terminal block.

K752 Outline Drawings

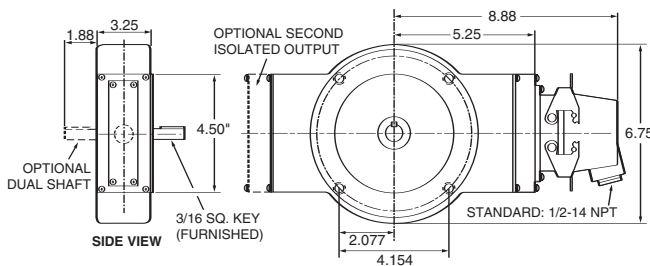

M485 Pulse Generator

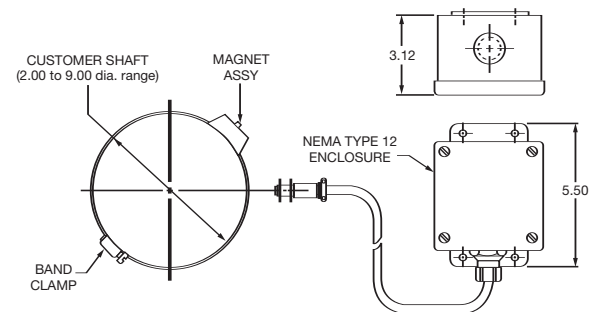

M185 UNIPULSER™

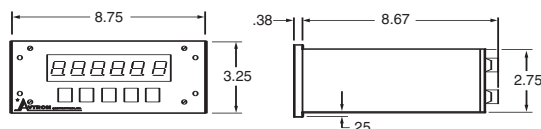

K752 – Panel Mounted

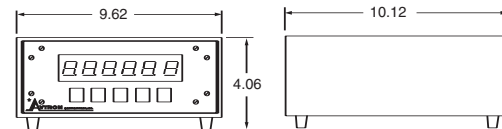

K752 – NEMA Enclosed Unit



UNIPULSER™ is a trademark of Avtron Mfg., Inc.
 Specifications and features subject to change without notice.
 All dimensions are in inches.
 Printed in U.S.A. Rev. A