

Wheel ID Table (ØB)

KAL1241-32-	Nominal ID (mm)	ID Tolerance ISO	ID Tolerance ±mm
06	6.00	H7	+0.01, -0.00
08	8.00	H7	+0.01, -0.00
10	10.00	H7	+0.01, -0.00
25	6.35	—	-0.01, -0.03
31	7.94	—	-0.02, -0.03
38	9.53	—	-0.02, -0.03

Wheel Reference Specifications

Mass	8	grams
Inertia	9	gram cm ²
Tensile Strength	480	kg/cm ² (ASTM D-638)
Flexural Strength	840	kg/cm ² (ASTM D-790)
Rockwell Hardness	R110	ASTM D-785

 Sensor mounting area. Free of components and traces (both sides).

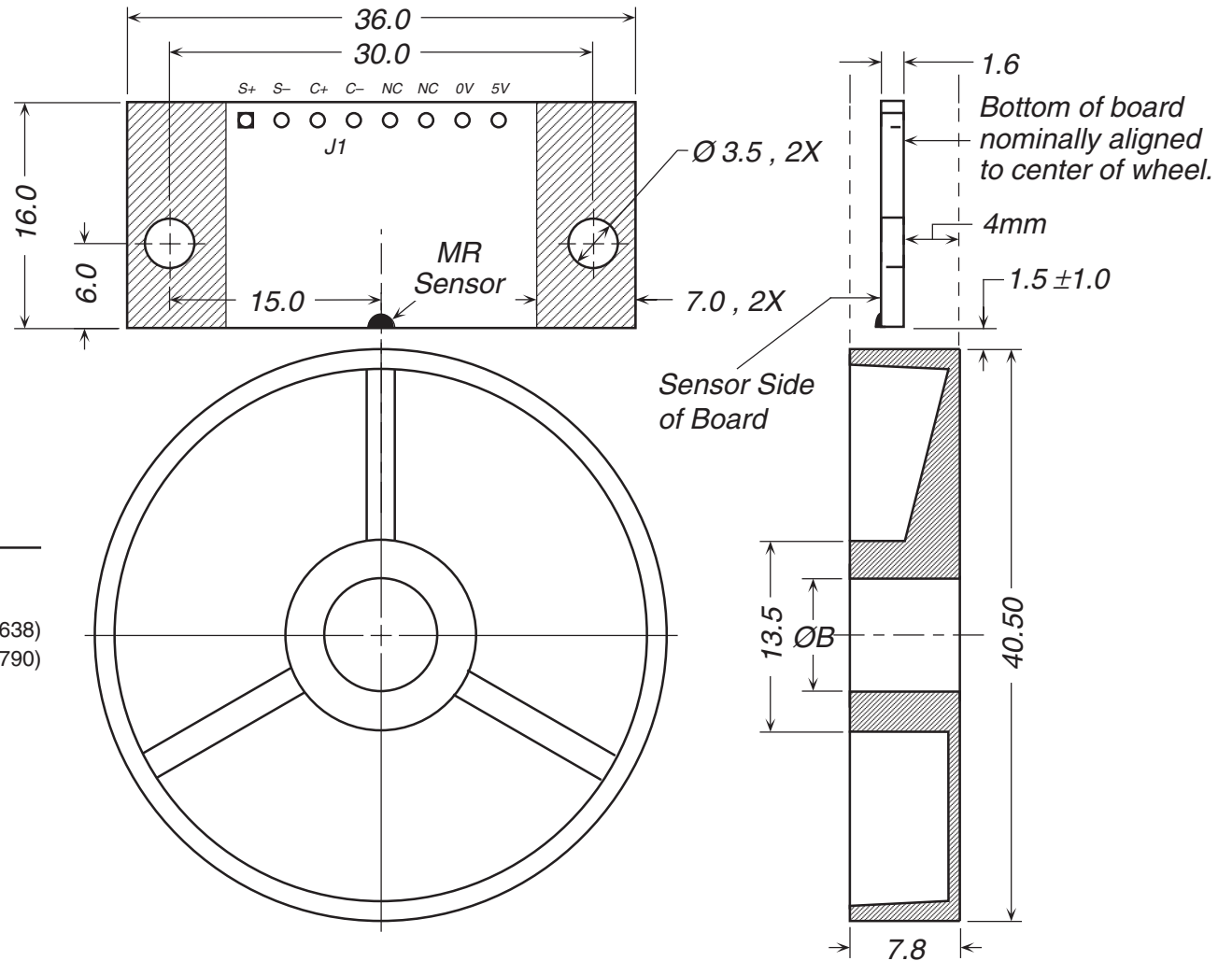

REFERENCE	DIMENSIONS IN MILLIMETERS TOLERANCES UNLESS OTHERWISE SPECIFIED		MATERIAL		admotec		
REVISIONS	.X: ± 0.10		As shown.		ADMOTEC INC., LEBANON NEW HAMPSHIRE USA		
	.XX: ± 0.05		HEAT TREAT Not applicable.		KAL1241 Encoder Outline & Mounting		
	ANGLES: ± 0°30'		FINISH Not applicable.				
	THIS DRAWING IS THE PROPERTY OF ADMOTEC INC. IT MAY NOT BE COPIED, USED OR DISCLOSED FOR ANY PURPOSE WITHOUT WRITTEN PERMISSION BY ADMOTEC INC.		DRAWN D Robinson	DATE 4 May 07	DRAWING SIZE A	7310-114	REVISION
			CHECKED	DATE			—
		APPROVED	DATE	SCALE 2:1			SHEET 1 OF 1