

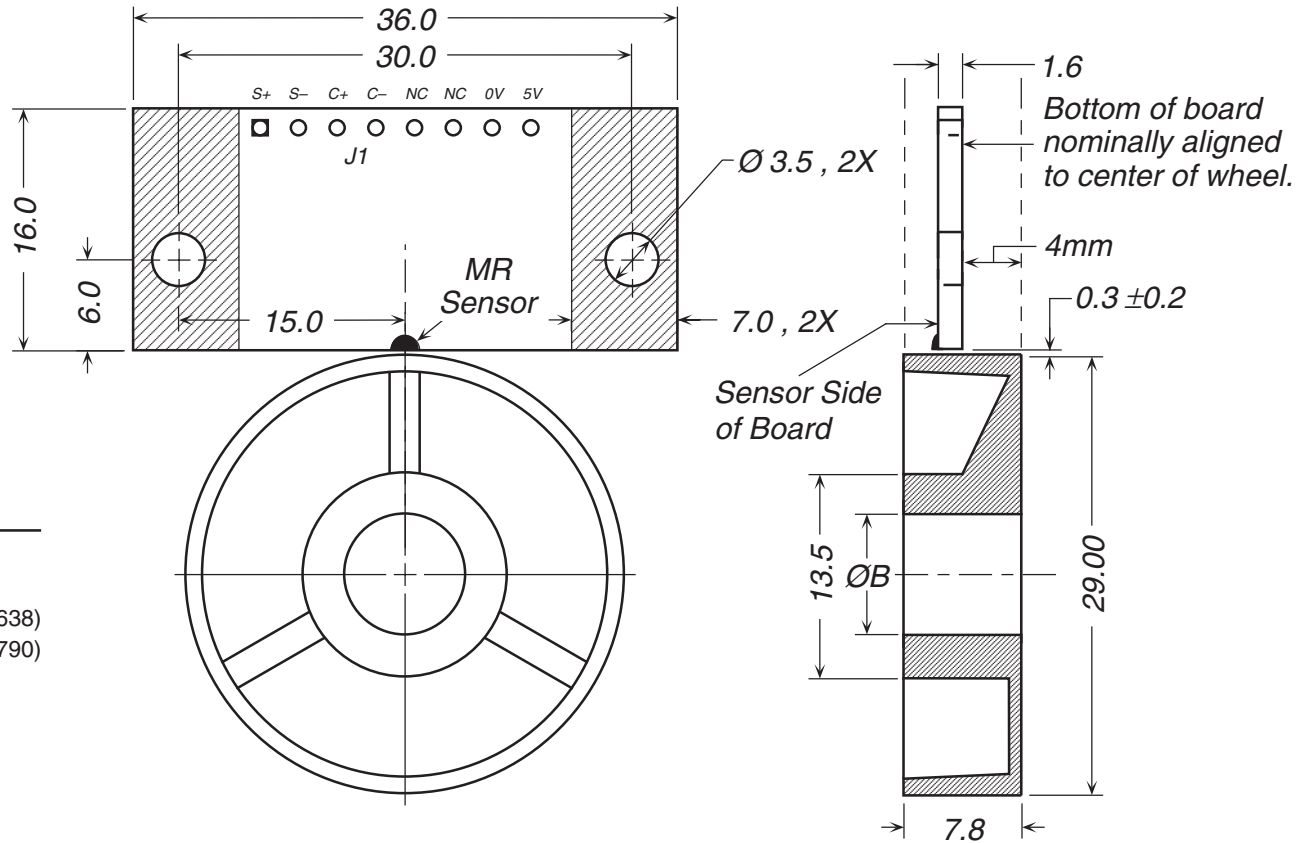

### Wheel ID Table (ØB)

KAS1229-90-	Nominal ID (mm)	ID Tolerance ISO	±mm
06	6.00	H7	+0.01, -0.00
08	8.00	H7	+0.01, -0.00
10	10.00	H7	+0.01, -0.00
25	6.35	—	-0.01, -0.03
31	7.94	—	-0.02, -0.03
38	9.53	—	-0.02, -0.03



### Wheel Reference Specifications

Mass	5	grams
Inertia	4	gram cm <sup>2</sup>
Tensile Strength	480	kg/cm <sup>2</sup> (ASTM D-638)
Flexural Strength	840	kg/cm <sup>2</sup> (ASTM D-790)
Rockwell Hardness	R110	ASTM D-785

 Sensor mounting area. Free of components and traces (both sides).

REFERENCE	DIMENSIONS IN MILLIMETERS TOLERANCES UNLESS OTHERWISE SPECIFIED		MATERIAL		admotec	
REVISIONS	.X: ± 0.10 .XX: ± 0.05 ANGLES: ± 0°30'		As shown.		ADMOTEC INC., LEBANON NEW HAMPSHIRE USA	
			HEAT TREAT Not applicable.		<b>KAS1229 Encoder Outline &amp; Mounting</b>	
THIS DRAWING IS THE PROPERTY OF ADMOTEC INC. IT MAY NOT BE COPIED, USED OR DISCLOSED FOR ANY PURPOSE WITHOUT WRITTEN PERMISSION BY ADMOTEC INC.		FINISH Not applicable.		DRAWING SIZE <b>A</b>		
			DRAWN D Robinson	DATE 4 May 07	7310-213	
			CHECKED	DATE	REVISION —	
			APPROVED	DATE	SCALE 2:1	SHEET 1 OF 1