

Avtron Model AV20

Optical, Solid Shaft Encoder

Setting a New Standard!

- Shaft Sizes include 1/4", 3/8", and 10mm
- Simple Installation
- Unbreakable Optical Disk
- Up to 16,384 PPR
- Wide-Gap Technology:
Up to 8X larger gap between sensor and rotor
- Replaces Competitive Models without Rewiring
- Industry Standard Face or Flange Mounting
- IP65/Nema 4 Rating: Dust and Liquid Tight
- Superior Bearings and Seals
- -40°C to +100°C Operation
- 2 Year No-Hassle Warranty

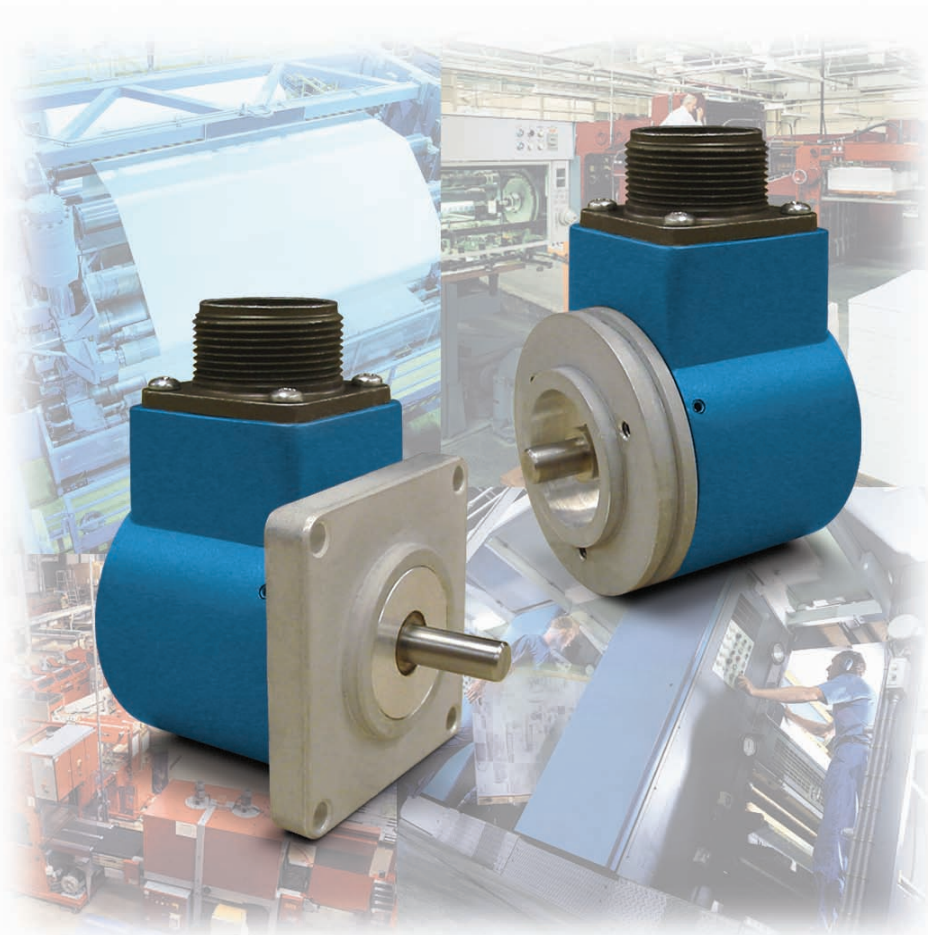

AV20 encoders look like industry standard units, and fit the same mounting patterns on all machines. That's where the similarity ends. Our AV20 encoders can withstand conditions that make other encoders fail. The solid aluminum housing, and stainless steel shaft offer increased durability in tough environments.

Avtron AV20 encoders have superior shaft seals and bearings that stay sealed to keep contaminants out,

through temperature cycling and liquid sprays. Our encoder seals are protected by mechanical barriers to prevent flexing or failure. Avtron's superior bearings permit much larger side and axial loads for pulley and belt applications, and feature synthetic lubricants for even longer life in all applications.

Many competitive optical encoder designs risk sensor damage from any vibration or shock: sensors ride less than four thousandths of an inch from

the thin, often flexible, optical disk spinning at full motor speeds. Some designs even use thin glass disks in "industrial" products! Avtron uses only unbreakable disks and a sensor to disk gap over 8X larger than the competition.

Our optical AV20 encoders are setting a new standard for quality, durability, and performance. Select an Avtron AV20 today!



QUALITY SYSTEM CERTIFIED TO ISO 9001
www.avtronencoders.com

AV20 Optical Solid Shaft Encoder (0.25" to 0.39") [6.35mm to 10mm]

OUTLINE DRAWING

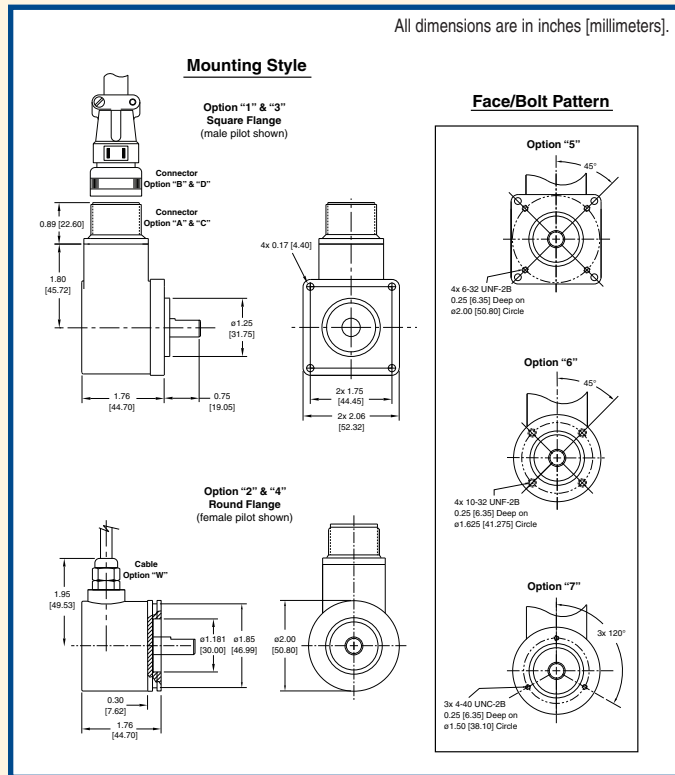

Check out our web site for more detailed specifications, drawings, and installation instructions. www.avtronencoders.com

MORE AV20 ADVANTAGES

- All-digital design, no trim pots or adjustments for longer life
- Advanced sensor technology
- Superior bearings with synthetic lubricant for longer life
- No extra charge for signal complements and marker pulse
- More than 2X the axial and side load capability of the competition
- Superior line drivers withstand short circuits and reverse voltage wiring errors

AV20 SPECIFICATIONS

Operating Power: Volts: 5 - 28 VDC; Current: 50mA, no load

Output Format: A Quad B with marker
(A, \bar{A} , B, \bar{B} , Z, \bar{Z}) available

Frequency Range: 0 to 125 KHz

PPR: 1 - 3600 Standard (for other PPR needs up to 16,384 consult factory)

Speed: 6000 RPM Max., (for higher speeds, consult factory)

Axial Load: 100 lbs [45 kg] max.

Radial Load: 100 lbs [45 kg] max.

Temperature: -40° to 100°C

Environment: Nema 4/IP65 (when provided with shaft seals)

Vibration: 5-2000 Hz

Shock: 50G, 11mS duration

Weight: 0.575 lbs [260 g]

CE

SELECTION GUIDE

AV20 PART NUMBERS AND AVAILABLE OPTIONS											
Mount	PPR*		Line Driver	Shaft Size	Connector Options	Wiring	Mounting Style	Face/Bolt Pattern	Seals	Channels	Special Features
AV20	A- 1 C- 25 F- 60 G- 100 H- 120 K- 200 L- 240 M- 250 N- 256 P- 300 E- 360 Q- 500 R- 512 S- 600	T- 625 U- 720 W- 1000 Y- 1024 Z- 1200 1- 1250 2- 1440 3- 2000 4- 2048 5- 2500 6- 2540 7- 3600 0- Special	1- 5-28V (7272) 2- 5-28V, open collector (7273) 4- 5-28V in, 5V out (7272)	0-Non-std. With Flat A- 0.25" B- 0.375" Without Flat N- 0.25" P- 0.375" R- 10mm	W- 18" cable (pigtail)	A- Side	1- Sq. Flange 2.06" w/ 1.25" male pilot 2- Rnd. Flange 2.0" w/ 1.25" male pilot 3- Sq. Flange 2.06" w/ 1.181" female pilot 4- Rnd. Flange 2.0" w/ 1.181" female pilot	X- None 5- 4x 6-32 @ 2" 6- 4x 10-32 @ 1.625" 7- 3x 4-40 @ 1.5"	A- Shaft Sealed** B- Bearing Sealed X- None^^	With Comp. A- A, \bar{A} , B, \bar{B} , Z, \bar{Z} *** B- A, \bar{A} , B, \bar{B} D- A, \bar{A} Without Comp. E- A, B, Z F- A, B	000- None 00W- Connector on 18" cable: Use w/ Option "T"- "U" 9xx- Specify cable length xx=feet (use w/ Option "W")
Connector Options											
Mounted on Encoder											
10 Pin MS			6 Pin MS			7 Pin MS			Mounted on 18" cable (00W)		
A- w/o plug (std. phasing) B- w/o plug (reverse phasing) C- w/ plug (std. phasing) D- w/ plug (reverse phasing)			E- w/o plug (std. phasing) F- w/o plug (reverse phasing) G- w/ plug (std. phasing) H- w/ plug (reverse phasing)			J- w/o plug (std. phasing) K- w/o plug (reverse phasing) M- w/ plug (std. phasing) N- w/ plug (reverse phasing)			T- w/o plug (Turck Pinout) U- w/o plug (US Pinout)		

* up to 16,384 PPR available

** recommended, N/A with Mounting Styles "3" & "4".

*** N/A with MS 6 or 7 Pin Connector.

^^ not recommended for industrial applications

All dimensions are in inches [millimeters].

Specifications and features are subject to change without notice.

