

# HS25A/HS35A/HS35M TETHER INSTALLATION

## READ ALL INSTRUCTIONS BEFORE PROCEEDING WITH INSTALLATION

- 1) DETERMINE TETHER MOUNTING POINT. SELECT A LOCATION THAT ALLOWS THE TETHER TO REST IN IT'S NATURAL POSITION, SO THAT IT IS NOT TWISTED OR STRETCHED.
- 2) USING A PHILLIPS SCREWDRIVER, MOUNT THE TETHER BRACKET TO THE FRONT OF THE ENCODER IN THE POSITION DESIRED, USING THE SCREWS AND LOCKWASHERS SUPPLIED.  
FOR HS35M ONLY, **DO NOT USE THREADLOCKER.**  
FOR INSTALLATIONS REQUIRING AN ACCESSORY GUARD, THE TETHER AND OUTPUT TERMINATION MUST BE POSITIONED AS SHOWN IN FIG 1a.  
FOR HS25A ONLY, TETHER MAY BE POSITIONED AS SHOWN IN FIG. 1b.
- 3) ENSURE THAT THE SHAFT IS CLEAN AND FREE OF BURRS. LOOSEN THE ENCODER SHAFT COLLAR. FOR HS25A AND HS35A, APPLY THREADLOCKER TO CLAMPING COLLAR SCREW. **DO NOT APPLY THREADLOCKER TO HS35M.**  
SLIDE THE ENCODER ONTO THE SHAFT UNTIL THE TETHER MEETS THE MOUNTING SURFACE OR MAXIMUM ENGAGEMENT HAS BEEN REACHED. SHAFT ENGAGEMENT MUST MEET THE MINIMUM REQUIREMENTS ESTABLISHED IN THE ENCODER INSTALLATION INSTRUCTIONS. IF TETHER DOES NOT REACH THE MOUNTING SURFACE, TAKE UP EXTRA SPACE USING FLAT WASHERS OR SPACERS. DO NOT TIGHTEN SCREW ON CLAMPING COLLAR.
- 4) ATTACH FREE END OF TETHER BRACKET TO A FAN COVER, MOTOR C-FACE OR MACHINE FRAME, AS REQUIRED. USE THE INSULATING WASHERS AND HARDWARE SUPPLIED TO SECURE THE TETHER. SEE FIGURES 2, 3 OR 4. CHECK TO ENSURE THAT THE TETHER IS IN A "NO STRESS" CONDITION, THEN FIRMLY TIGHTEN CLAMP COLLAR SCREW TO 35-40 LB-IN USING T-HANDLE HEX WRENCH. **DO NOT USE RIGHT ANGLE HEX WRENCH.**
- 5) CUSTOMER SUPPLIED TETHERS MUST ALLOW THE ENCODER TO MOVE AXIALLY AND RADIALLY A MINIMUM OF  $\pm 0.10$  WHILE PREVENTING ROTATION. EXCESS OR RESTRICTED MOVEMENT WILL CAUSE PREMATURE BEARING FAILURE. IT IS RECOMMENDED THAT INSULATED HARDWARE BE USED TO ELECTRICALLY ISOLATE THE ENCODER MOUNTING FROM THE MACHINE.

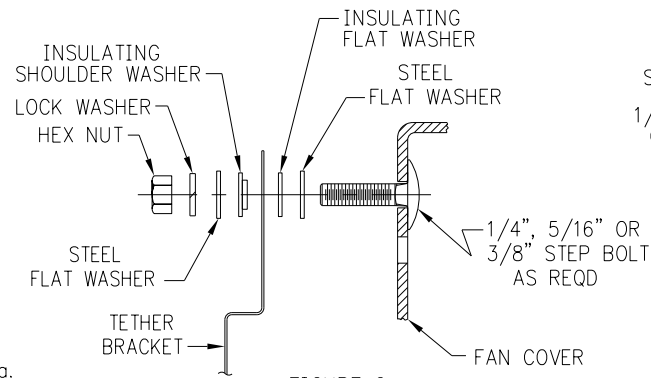

FIGURE 2a  
FAN COVER MOUNT

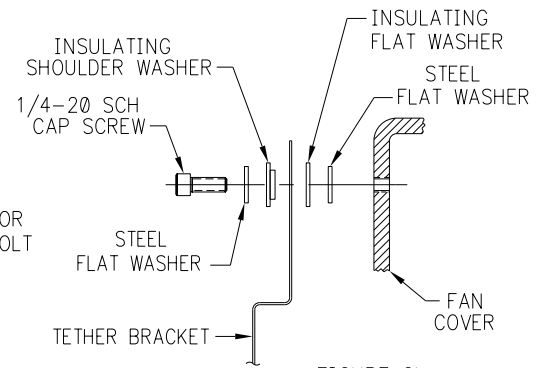

FIGURE 2b  
FAN COVER MOUNT  
WITH THREADED HOLE

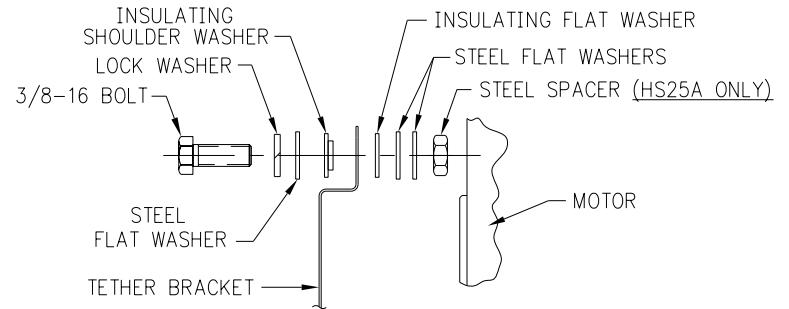

FIGURE 3  
MOTOR HOUSING MOUNT  
NEMA 4.50 C-FACE

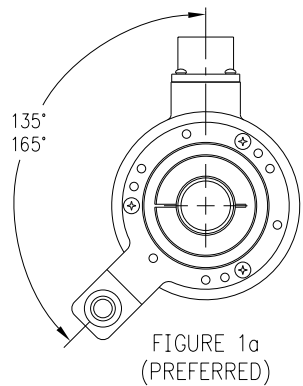

FIGURE 1a  
(PREFERRED)

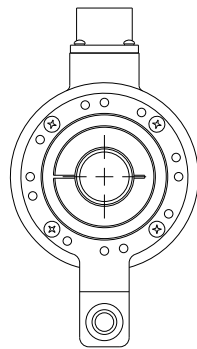

FIGURE 1b  
(ALTERNATE)  
(HS25A ONLY)

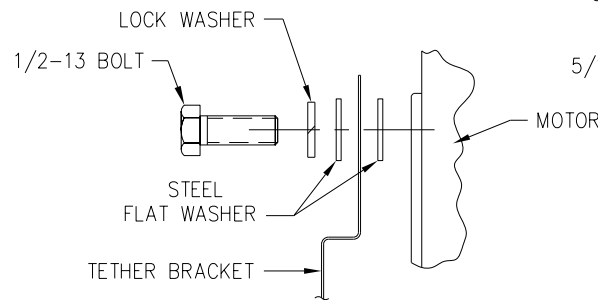

FIGURE 4  
MOTOR HOUSING MOUNT  
8.50 C-FACE  
HS35M ONLY

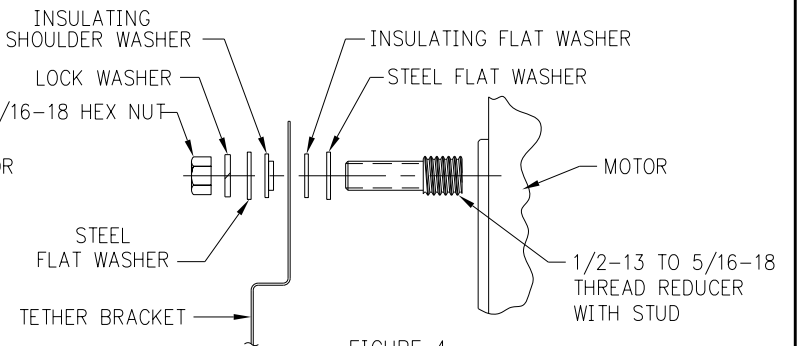

FIGURE 4  
MOTOR HOUSING MOUNT  
8.50 C-FACE  
HS25A & HS35A ONLY