



8901 E. PLEASANT VALLEY ROAD
 INDEPENDENCE, OHIO 44131-5508
TELEPHONE: (1) 216-642-1230 • **FAX:** (1) 216-642-6037
E-MAIL: tachs@avtron.com • **WEB:** www.avtronencoders.com

Encoder Instructions

HS25A

3/8" to 3/4" [6mm-16mm]
 HOLLOW SHAFT

DESCRIPTION

The Avtron Model HS25A Hollow Shaft Rotary Incremental Encoder is a speed and position incremental transducer (also known as tachometer or rotary pulse generator). When mounted to a motor or machine, its output is directly proportional to shaft position (pulse count) or speed (pulse rate). The HS25A operates down to zero speed and can be used for both control and instrumentation applications.

The HS25A employs a hollow shaft and clamping collar to lock the encoder to the shaft. A high-performance resin hollow shaft insert provides electrical isolation from motor shaft currents and permits models to fit a broad range of shaft sizes from 3/8" to 5/8" [6mm - 16mm]; 3/4" [20mm] is permitted by omitting any insert. An anti-rotation bracket prevents rotation of the encoder while allowing for shaft end float and axial movement.

The HS25A encoder offers 2Ø outputs (A,B) 90° apart for direction sensing (A Quad B), with complements (Ā,Ḃ), and with marker pulse and complement (Z,Z̄).

INSTALLATION CONSIDERATIONS

See page 3 and drawing on last page for shaft engagement rules. Shaft may include keyway, but should not be flatted.

The HS25A offers optional Avtron flexible anti-rotation tethers/brackets which will permit the encoder to tolerate ±0.1" of shaft end float/axial movement. Select the proper tether for the application from the table below.

CAUTION

Be careful not to damage clamping fingers of hollow shaft during handling. Do not tighten clamping collar before installation onto motor shaft.

Equipment Needed for Installation

Provided	Optional	Not Provided
HS25A Encoder	Anti-Rotation Tether Kit	#2 Phillips Screwdriver
Clamping Collar	Shaft Sizing Insert	9/64" Hex Wrench (US)
Thread Locker (blue)	Mating MS Cable Connector	3mm Hex Wrench (metric) (T-Handle Style)
	Protective Basket Kit	Caliper Gauge
	Anti-Seize (copper) (HS25A 0.750" only)	Dial Indicator Gauge
		7/16", 9/16", 5/8", 3/4", 10mm Wrenches (tether options)

WARNING

Installation should be performed only by qualified personnel. Safety precautions must be taken to ensure machinery cannot rotate and all sources of power are removed during installation.

WARNING

Be certain to identify thread locker and anti-seize compound correctly. Using anti-seize in place of thread locker can cause mechanical failure leading to equipment failure, damage, and harm to operators.

INSTALLATION

Refer to the back page of these instructions for outline and mounting dimensions. Also available: EU (European Union) Installation Sheet and Basket Mount Installation Sheet. NOTE: For metric bore sizes, the encoder is provided with metric size hardware. For US bore sizes, the encoder is provided with US size hardware.

HS25A PART NUMBERS AND AVAILABLE OPTIONS

Mount	PPR*	Line Driver	Bore Options	Connector Options	Mounting Style	Protection	Anti-Rotation Tether Options	Channels	Special Features	
HS25A	A- 1 C- 25 F- 60 G- 100 H- 120 K- 200 L- 240 M- 250 N- 256 P- 300 E- 360 Q- 500 R- 512 S- 600	T- 625 U- 720 V- 900 W- 1000 Y- 1024 Z- 1200 1- 1250 2- 1440 3- 2000 4- 2048 5- 2500 6- 2540 7- 3600 0- Special	1- 5-28V, Open Collector 2- 5-28V, 5V out 3- 2000 4- 2048 5- 2500 6- 2540 7- 3600 0- Special	0- Non-std. Shaft L- 6mm M- 8mm N- 10mm P- 12mm Q- 14mm S- 16mm U- Universal 3/8" to 3/4" (all inserts) Z- Metric 6mm to 16mm (all inserts)	W- 18" flex. cable	E- End of Shaft	0- None 1- basket	X- None A- Fan cover, 1/4-20 B- Fan cover, 5/16-18 C- Fan cover, 3/8-16 D- Fan cover, all E- 4.5" or 6.75" C-Face F- 8.5" C-Face U- Universal (all tether options)	A- A, Ā, B, Ḃ, Z, Z̄ B- A, Ā, B, Ḃ, C D- A, Ā E- A, B, Z F- A, B, C	000- None 9xx- Specify cable length xx=feet (use w/ Option "W")
	Connector Options									
				10 Pin MS		6 Pin MS		7 Pin MS		8 Pin M12
				A- w/o plug (std. phasing) B- w/o plug (Dynapar HS35 phasing) C- "A" w/ plug D- "B" w/ plug		E- w/o plug (std. phasing) F- w/o plug (Dynapar HS35 phasing) G- "E" w/ plug H- "F" w/ plug		J- w/o plug (std. phasing) K- w/o plug (Dynapar HS35 phasing) M- "J" w/ plug N- "K" w/ plug		T- w/o plug (Turck Pinout) U- w/o plug (US Pinout)

*up to 8192 PPR available
 *only available with MS 6 and 7 pin connectors
 **No insert

- 1) Disconnect power from equipment and encoder cable.
- 2) Use caliper gauge to verify motor shaft is proper diameter and within allowable tolerances: +0.000", -0.0005" [+0.00, -0.13mm].
- 3) Clean machine shaft of any dirt and remove any burrs.
- 4) Use dial indicator gauge to verify the motor shaft Total Indicated Runout (TIR) < 0.002".
- 5) Install the anti-rotation bracket to the face of the encoder using 6-32 screws and thread locker.
- 6) Loosen clamping collar and insert shaft sizing insert into encoder. **DO NOT FORCE**. (NOTE: To fit an HS25A on a 0.75" shaft, use no insert.)
- 7) Test Fitting: carefully slide the encoder onto the shaft to verify fit. Ensure a minimum of 1/8" between encoder and mounting surface. **DO NOT FORCE**. Encoder should slide on easily. If the encoder does not fit easily, remove it, verify shaft size, and check for burrs and shaft damage.
- 8) *Special Note for 0.75" shaft in HS25A ONLY:*
Remove encoder, apply anti-seize compound to shaft and reinstall encoder, leaving a minimum of 1/8" between motor face and encoder (see "Shaft Engagement").
- 9) Apply thread locker to screw on clamping collar. Tighten screw on clamping collar evenly until snug, then tighten each screw to 35-50 in-lb [4-6 Nm]. **DO NOT USE A STANDARD RIGHT ANGLE WRENCH**. Use only a T-handle hex wrench or torque wrench with hex bit. Note: Units shipped with a metric bore size require a 3mm T-handle hex wrench, units with US size bores, a 9/64" T-handle hex wrench.
- 10) Secure free end of anti-rotation bracket to frame. Use insulating hardware as shown (supplied with Avtron anti-rotation kit). Use additional washers as needed to install the bracket without a large deflection or bend. For 8.5" C-Face, install

1/2"-13 to 3/8"-16 reducer with 3/8"-16 threaded stud (supplied) to secure anti-rotation bracket using insulating hardware as shown.

- 11) Turn shaft by hand and verify the shaft turns freely and does not produce excessive runout/wobble of the encoder: <0.005" TIR (Total Indicator Reading). Additional instructions under "Adjusting the Encoder to Eliminate Excess Runout/Wobble" are provided if needed.
- 12) *Optional:* Attach Avtron Encoder/Tachometer Tester unit (B27609) using factory-provided cable. Follow tester instructions to check direction of rotation, proper output, PPR, and signal quality.
- 13) Connect cable as shown in wiring diagram.
- 14) Apply power (5-28VDC) to the encoder.
- 15) Rotate the shaft by hand, or using jog mode of the speed controller and verify proper direction.
- 16) *Optional:* Install Protective Basket using either T-bolts (Fan Cover) or bolt to 4.5" C-Face (bolts provided). For 8.5" C-Face use adapter clips supplied. Be certain that the Protective Basket does not touch or interfere with the anti-rotation arm.
To mount the basket on an 8.5" C-face, thread the 1/2"-13 bolts into the motor face, through each clip (provided with options "F" and "U") but do not tighten fully. Pivot the basket over the encoder, and pivot each clip over each respective basket bolt hole. **DO NOT FORCE**. Tighten each bolt to secure the basket and clip.

Adjusting the Encoder to Eliminate Excess Runout/Wobble:

In a typical installation, a housing movement of 0.005" TIR or less (as measured at the outside diameter of the main encoder body) will not have an adverse effect. If excessive housing movement is detected in the installation:

SPECIFICATIONS

ELECTRICAL

- A. Operating Power (Vin)
 1. Volts.....5-28V
 2. Current50mA, no load
- B. Output Format A Quad B with marker (A, \bar{A} , B, \bar{B} , Z, \bar{Z})
- C. Signal Type Incremental, Square Wave, 50% \pm 10% Duty Cycle
- D. Direction Sensing Phasing with respect to rotation as viewed from the back of the encoder (non-clamping collar side).
Connector options "A", "C", "E", "G", "J", "M", "U" & "W": \emptyset A leads \emptyset B for CW rotation (Std. phasing).
Connector options "B", "D", "F", "H", "K", "N", "T": \emptyset A leads \emptyset B for CCW rotation (Dynapar HS35 phasing).
- E. Transition Sep.....15% minimum
- F. Frequency Range.....0 to 125kHz.
- G. PPR.....1 - 3600 standard (for other PPR needs up to 8192 consult factory)
- H. Output.....See Line Driver Options

MECHANICAL

- A. Acceleration.....6,000 RPM/Sec.
- B. Speed6,000 RPM max. (for higher RPM needs, Consult Factory)
- C. Shaft Diameter0.375" to 0.750" [6mm to 19mm]
- D. Shaft Engagement.....1.000" to 1.300" [25mm-33mm]
- E. Weight0.95 lbs. (431g)
- F. Starting Torque @ 25C...5oz in [0.035n-m] Max

ENVIRONMENTAL

- A. Enclosure Rating.....NEMA 4, 13, IP65 (dust and water tight, not for immersion)
- B. Operating Temp.....-20 to +100°C
- C. Humidity98% Non-condensing
- D. Shock50G, 11 ms Duration
- E. Vibration.....5-2000Hz @ 20G

LINE DRIVER OPTIONS

		Output Options		
		1	2	4
Output Type		Differential Line Driver	Open Collector	Differential Line Driver, 5V fixed
Line Driver		7272	7273	7272
Voltage Input (Vin)		5-28VDC	5-28VDC	5-28VDC
Protection	Reverse Voltage	Yes	Yes	Yes
	Transient	Yes	Yes	Yes
	Short Circuit	Yes	Yes	Yes
Maximum Cable length*		5V 1000 ft 12V 500 ft 24V 200 ft	see note*	200 ft



HS25A WIRING DIAGRAMS

LINE DRIVER (Options 1 & 4) DIFFERENTIAL TWO PHASE WIRING APPLICATIONS

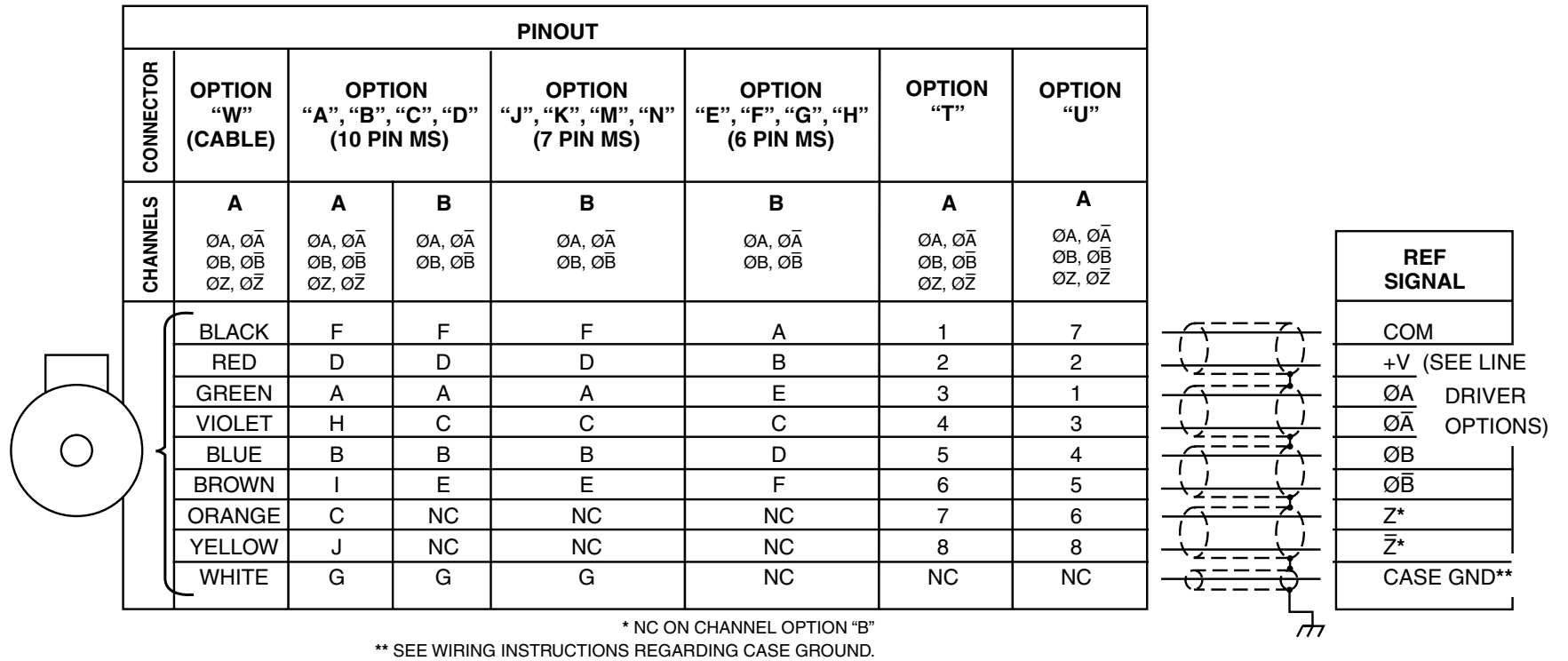

TYPICAL WIRE SELECTION CHART for 18 AWG, multiple pair, individually shielded

	BELDEN	ALPHA
2 PAIR	9368	6062C
3 PAIR	9369	6063C
4 PAIR	9388	6064C
6 PAIR	9389	6066C

For Connector Option "W", unused connections must be insulated to prevent accidental contact.

* **NOTE:** Connecting Case Ground is optional.

HS25A WIRING DIAGRAMS

LINE DRIVER (Options 1,2,^ & 4) SINGLE ENDED TWO PHASE WIRING APPLICATIONS, WITH OR WITHOUT MARKER

^ Open Collector Line Driver Output Option 2 requires pull up resistors from each active output to a +V reference.

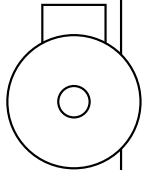
PINOUT						
CONNECTORS	OPTION "W" (CABLE)	OPTION "A", "B", "C", "D" (10 PIN MS)	OPTION "J", "K", "M", "N" (7 PIN MS)	OPTION "E", "F", "G", "H" (6 PIN MS)	OPTION "T"	OPTION "U"
CHANNELS	A ØA, ØĀ ØB, ØB̄ ØZ, ØZ̄	E, F ØA, ØB, ØZ	E, F ØA, ØB, ØZ	E, F ØA, ØB, ØZ	A ØA, ØĀ ^ ØB, ØB̄ ^ ØZ, ØZ̄ ^	A ØA, ØĀ ØB, ØB̄ ØZ, ØZ̄
	RED	D	D	B	2	2
	BLUE	B	B	D	5	4
	GREEN	A	A	E	3	1
	BLACK	F	F	A	1	7
	ORANGE*	C*	C*	C*	7	6
	WHITE	G	G	NC	NC	NC

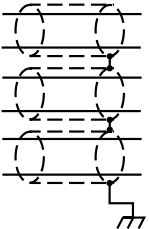

REF SIGNAL
+V (SEE LINE DRIVER OPTIONS)
ØB
ØA
COM
ØZ*
CASE GND**

* NC ON CHANNEL OPTION "F"
 ** SEE WIRING INSTRUCTIONS REGARDING CASE GROUND.
 ^ COMPLEMENTS INCLUDED BUT NOT USED

LINE DRIVER (Options 1,2,^ & 4) SINGLE ENDED SINGLE PHASE WIRING APPLICATIONS

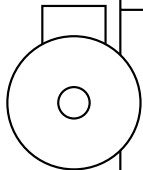
PINOUT						
CONNECTORS	OPTION "W" (CABLE)	OPTION "A", "B", "C", "D" (10 PIN MS)	OPTION "J", "K", "M", "N" (7 PIN MS)	OPTION "E", "F", "G", "H" (6 PIN MS)	OPTION "T"	OPTION "U"
CHANNELS	A (ØĀ, ØB, ØB̄, ØZ, ØZ̄ INCLUDED BUT NOT USED)	D ØA (ØĀ INCLUDED BUT NOT USED)	D ØA (ØĀ INCLUDED BUT NOT USED)	D ØA (ØĀ INCLUDED BUT NOT USED)	A (ØĀ, ØB, ØB̄, ØZ, ØZ̄ INCLUDED BUT NOT USED)	A (ØĀ, ØB, ØB̄, ØZ, ØZ̄ INCLUDED BUT NOT USED)
	BLACK	F	F	A	A	A
	RED	D	D	B	B	B
	GREEN	A	A	E	E	E
	WHITE	G	G	NC	NC	NC

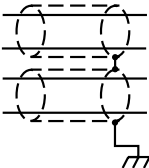

REF SIGNAL
COM
+V (SEE LINE DRIVER OPTIONS)
ØA
CASE GND**

** SEE WIRING INSTRUCTIONS REGARDING CASE GROUND.

- 1) Check the shaft the HS25A is mounted on for excessive shaft runout. NEMA MG1 calls for 0.002" TIR or less.
- 2) Verify that the mounting shaft meets minimum and maximum diameter tolerances.
- 3) Maximize the shaft insertion into the encoder (retaining the minimum of 1/8" between mounting face and encoder)
- 4) Loosen the clamping collar and rotate the motor shaft 180° within the encoder hollow shaft sleeve. Retighten the clamping collar.
- 5) Loosen the clamping collar; move the split in the clamping collar over a solid portion of the encoder shaft, retighten the clamping collar.

If excessive housing movement still exists after the above steps, it may be necessary to physically bias the attitude of the encoder on the motor shaft while the clamping collar is being tightened.

Shaft Sizes:

HS25A: 0.375", 0.500", 0.625", 0.750"*, 6mm, 8mm, 10mm, 12mm, 14mm, 16mm

NOTE: HS25A units utilize shaft insulating resin insert; models from 0.375" to 0.625" [6mm to 16mm] may be resized as needed by interchanging inserts.

* HS25A at 0.750" [19mm] does not utilize shaft insulating insert: use insulating washers with anti-rotation bracket to achieve electrical isolation from shaft currents.

Consult factory for other shaft sizes not shown.

Shaft Engagement:

HS25A: Shaft insertion/engagement should be 1.0" to 1.3" [25mm to 33mm] (maximum), with a minimum of 1/8" [3mm] between encoder and mounting surface.

For shaft lengths greater than the maximum engagement allowed, end of shaft mounting may still be employed by using a spacer between the mounting surface and anti-rotation bracket.

WIRING INSTRUCTIONS

CAUTION

Be sure to remove power before wiring the HS25A Encoder.

Be sure to ground the cable shield(s): It can be connected to case ground at the encoder, or grounded at the receiving device, but should not be grounded on both ends.

If necessary, case ground can also be provided through a separate wire. Be certain not to ground the case ground wire if the encoder is already grounded by mechanical mounting. (The standard antirotation arm kits provide insulating washers)

The HS25A encoder can be wired for single phase or two-phase operation, either with or without complements, with or without markers. See connector options and wiring diagrams.

CAUTION

When wiring for differential applications (A, \bar{A} , B, \bar{B} , Z, \bar{Z}), A and \bar{A} should be wired using one twisted, shielded pair; B and \bar{B} should be in a second pair, etc. Failure to use complementary pairs (say, using A and B in a twisted pair) will reduce noise immunity significantly.

For encoder output that correctly reflects the direction of rotation, proper phasing of the two output channels is important. Phase A channel leads phase B channel for clockwise shaft rotation as viewed from the back (non-mounting side) of the encoder for standard phasing options ("A", "C", & "W"). Follow instructions under corrective installation as needed to reverse the direction of output or purchase HS35M with reverse (Dynapar HS35) phasing (options "B", "D").

CORRECTIVE ACTION FOR PHASE REVERSAL

If Encoder Direction is Reversed:

- 1) Remove power.
- 2) Exchange wires on cable, either at encoder cable end, or at speed controller end (but NOT both):
 - a.) **Single Ended 2 Phase Wiring** (see wiring diagram) Exchange A and B at the user end of the wires.
 - b.) **Differential 2 Phase Wiring** (see wiring diagram) Exchange **either** A with \bar{A} in the phase A pair **OR** B with \bar{B} in the phase B pair but **NOT** both.
- 3) Apply power.
- 4) Verify encoder feedback is correct, using hand rotation of shaft, or jog mode of the speed controller.

Interconnecting cables specified in the wire selection chart are based on typical applications. Refer to the "Wiring Diagrams" below for suggested cable types. General electrical requirements are: stranded copper, 22 thru 16 gauge, each wire pair individually shielded with braid or foil with drain wire, 0.05 uF maximum total mutual or direct capacitance, outer sheath insulator.

OUTLINE DRAWINGS

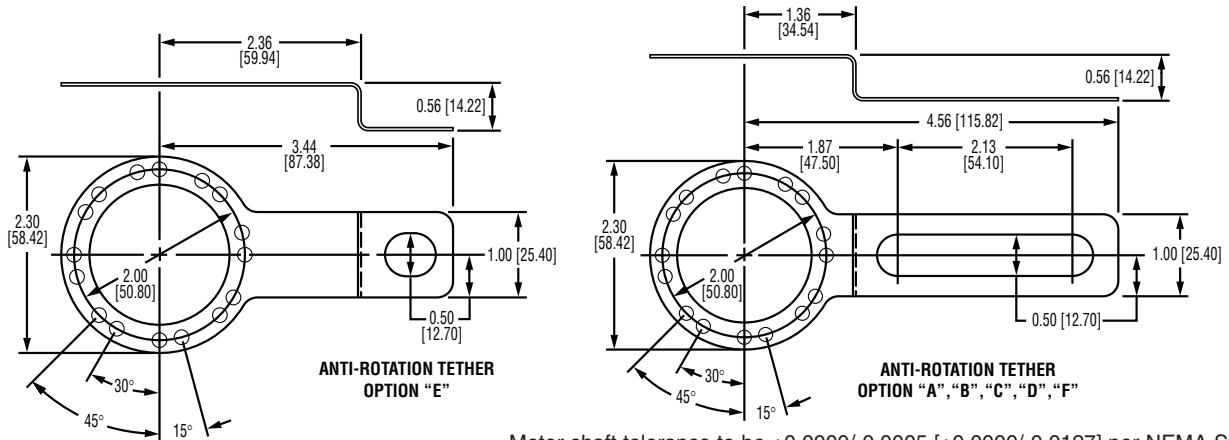
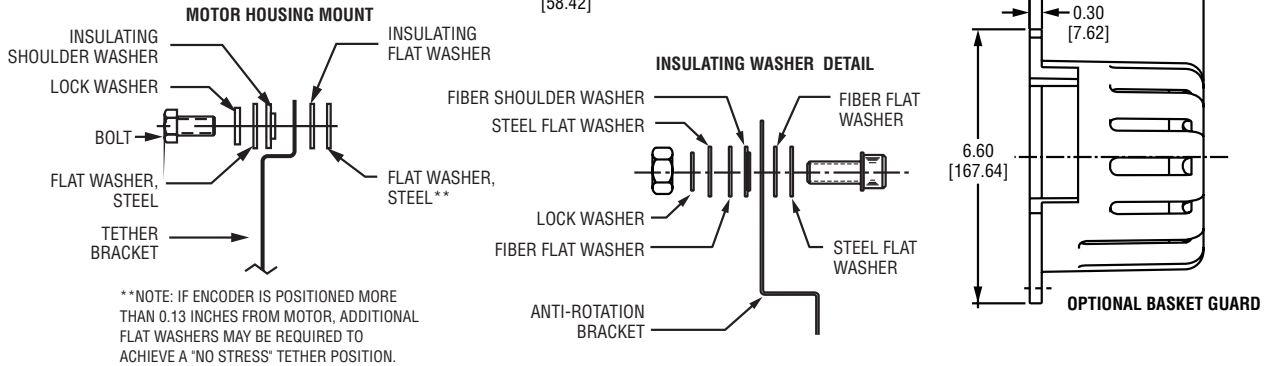
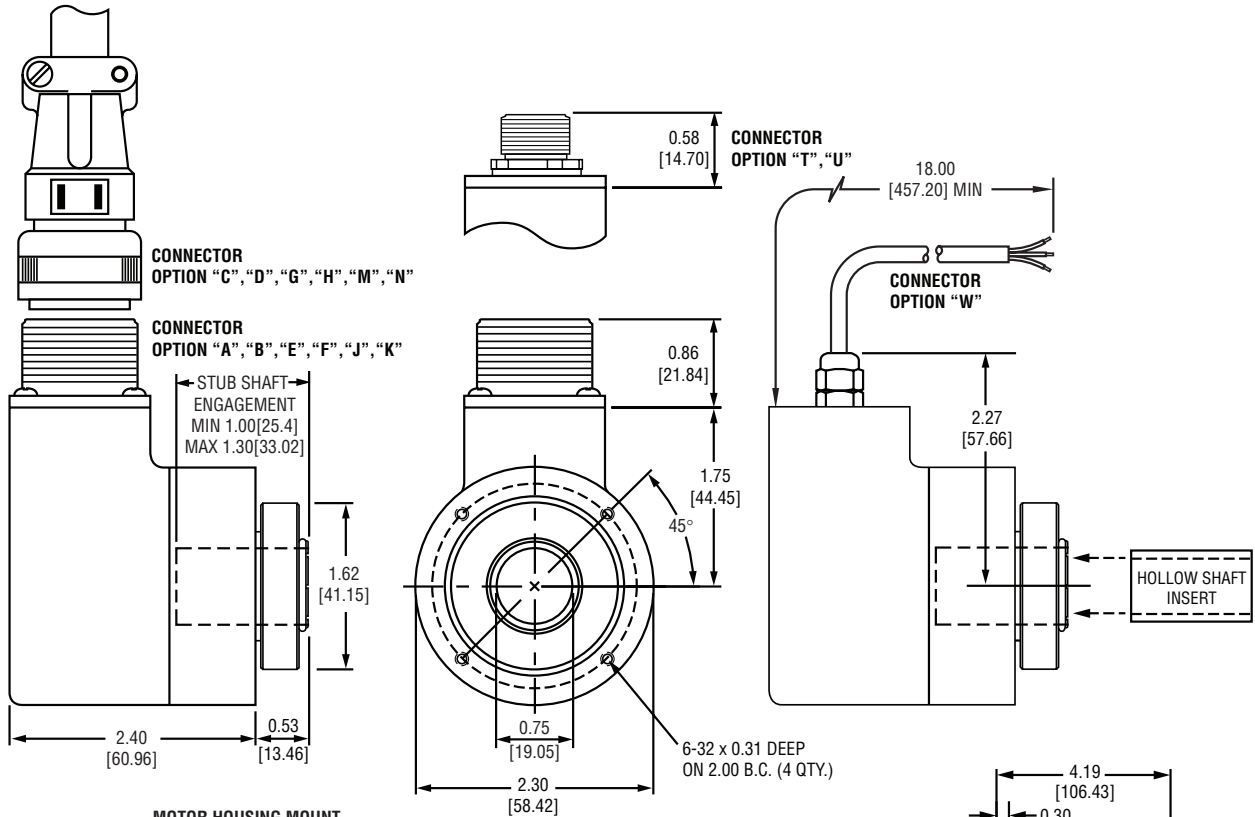

Motor shaft tolerance to be +0.0000/-0.0005 [+0.0000/-0.0127] per NEMA Std. MG1.

All dimensions are in inches [millimeters].
Avtron standard warranty applies. Copies available upon request. Specifications subject to change without notice.