



8901 E. PLEASANT VALLEY ROAD  
 INDEPENDENCE, OHIO 44131-5508  
 TELEPHONE: (216) • 642-1230  
 FACSIMILE: (216) • 642-9743

FOR SERVICE:  
 CALL (216) • 641-8310

## Pulse Generator Instructions

### M185 Unipulser™

### DESCRIPTION

The Model M185 Unipulser is a single pulse per revolution, zero speed (operational down to zero RPM) pulse generator which requires no coupling to the shaft for which rotational speed is being measured. The pulse generator consists of a magnet assembly which clamps around the shaft and a transducer assembly which mounts in proximity to the magnet assembly. Refer to the Outline Drawing (Figure 2) for specific dimensional information.

The Model M185 is designed for applications where an end shaft is not available for coupling to other types of rotary pulse generators. When the M185 is used in conjunction with a speed measuring system

like the Avtron Model K885, it is possible to measure roll surface speed to 0.01%, with a 1 second measurement period for any shaft speed from 60 to 3000 RPM.

The magnet assembly is supplied with an adjustable fastener and sufficient band material to accommodate shafts ranging in diameter from 2 inches to 9 inches. For smaller diameter shafts, a hose clamp (not included) with a 0.5 inch wide band may be used. For larger diameter shafts, longer lengths of band material are available from the factory.

### M185 SPECIFICATIONS

<b>OPERATING POWER</b> .....	5-15 VDC @ 30 mA
<b>PULSES PER REVOLUTION (PPR)</b> .....	1
<b>MAX FREQUENCY OUTPUT</b> .....	50 Hz
<b>SPEED RANGE</b> .....	0 to 3000 RPM
<b>OPERATING TEMPERATURE</b> .....	32°F to 150° F
<b>OUTPUT SIGNAL</b>	
<b>WAVE SHAPE</b> .....	Square
<b>VOLTS OUT HIGH</b> .....	Supply Volts
<b>VOLTS OUT LOW</b> .....	0.5 VDC Max @ 10 mA
<b>IMPEDANCE</b> .....	1.2 K pull up 10 mA sink
<b>DUTY CYCLE</b> .....	Normally high. Switches low when sensing magnet.
<b>WEIGHT</b>	
<b>MAGNET ASSEMBLY</b> .....	1 oz.
<b>TRANSDUCER ASSEMBLY</b> .....	2.5 lbs.

SPECIFICATIONS SUBJECT TO CHANGE WITHOUT NOTICE

## UNPACKING INSTRUCTIONS

The M185 consists of three or four loose items, depending upon the style of magnet assembly supplied. These items are packed inside the NEMA 12 type enclosure.

### Style 1:

1. Magnet assembly (plastic)
2. Adjustable fastener
3. Band material

### Style 2:

1. Magnet assembly (metal)
2. Magnet retainer
3. Adjustable fastener
4. Band material

## MAGNET ASSEMBLY INSTALLATION

If a plastic magnet assembly is being installed, then pass the band material through the slots of the plastic magnet assembly so the band is routed under the magnet base.

In the case of the metal magnet assembly, insert the magnet assembly through the center hole of the magnet retainer. Pass the band material through the slots in the magnet retainer so the band passes under the magnet.

Adjust the adjustable fastener so roughly 1-1/2 inch of the adjustable strap material extends past the adjusting device. Hook one end of the adjustable fastener strap in the end rectangular cutout of the band material.

Temporarily position the band around the shaft so it fits flush against the outer diameter. Select the closest rectangular cutout for the other end of the adjustable fastener. Cut and discard excess band material. Remove the band from the shaft and separate the adjustable fastener. Hook the loose end of the adjustable fastener in the last band cutout.

Position the band and magnet assembly around the shaft and select its operational location. Insure that enough space is allowed for installing the mounting bracket for the transducer assembly. Verify that the band is perpendicular to the machine roll axis, and secure by tightening the adjustable fastener.

## TRANSDUCER ASSEMBLY INSTALLATION

The transducer assembly is designed to be mounted within 0.04 to 0.16 inch from the magnet assembly as shown in the Outline Drawing, Figure 2.

The transducer must be installed in a manner that will prevent it from moving due to vibration. Excessive transducer vibration can affect signal accuracy and may damage the transducer if it comes in contact with the rotating magnet assembly.

A solid mounting support must be fabricated and positioned so it is out of the way, preferably under the shaft, to prevent it from being used as a step or footrest by machine personnel. This position also has the advantage of preventing damage to the transducer should the bracket flex.

The support stand described below is presented only as an example of how a support can be fabricated. As each installation is different, the design and fabrication of the support are left to the individual user.

For heights less than 12 inches, refer to Figure 1. The support stand can be made of 1-inch pipe and a standard pipe flange attached to an 8-inch square, 1/4-inch thick base plate. The transducer mounting plate can be made of a flat plate (A) with a 7/8-inch hole drilled for mounting the transducer. Transducer mounting plate (B) shown should only be used when absolutely necessary.

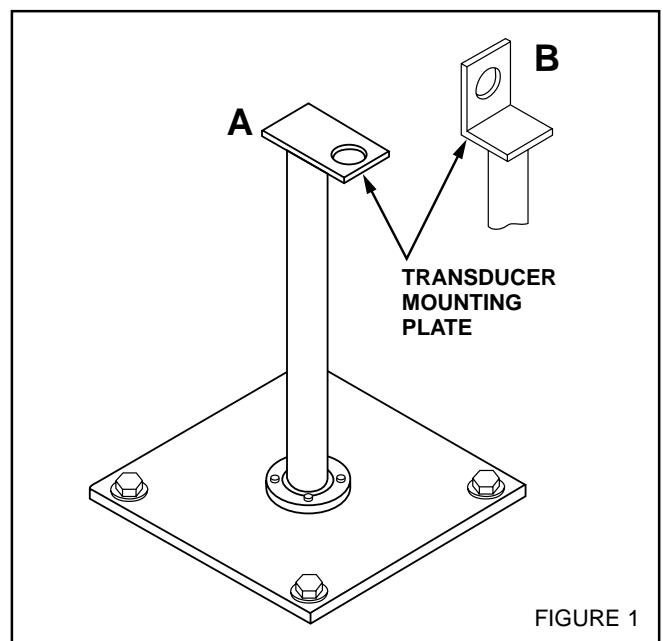

For heights greater than 12 inches, the base plate dimensions should increase. Also, angle iron braces, welded between the top of the pipe and the base plate, should be added.

When the support stand is ready, position it so the transducer mounting plate is located at approximately 5/8 inch from the magnet assembly. Secure the support stand to the floor.

Install the transducer in the mounting plate with two locknuts. Adjust the gap between the transducer and the magnet tip to dimensions shown in Figure 2, and secure the transducer to the mounting plate.

### WARNING

*A guard must be installed surrounding the magnet assembly and the transducer to protect operating personnel. Guards are not available from Avtron as they must be tailored for each installation.*

## WIRING

Interconnection cables specified in the wiring diagram below are based on typical applications. Refer to system drawings for specific cable requirements where applicable. Physical properties of cable such as abrasion, temperature, tensile strength, solvents, etc., are dictated by the specific application. General electrical requirements are: stranded copper, 22 thru 16 gage, braid or foil with drain wire shielding, 0.05 uF maximum total mutual or direct capacitance, outer sheath insulator; length: 1000 ft. maximum. The customer-supplied cable must be retained to the NEMA 12 box with a watertight fitting.

### CAUTION

*The rubber jacketed transducer cable has been selected to provide impact and abrasion resistance. Also, strain relief is provided at the transducer cable entrance to the NEMA 12 type terminal box and at the transducer. The transducer cable, however, should be protected from severe impact, abrasion, and chemical stress.*

## WIRING DIAGRAM

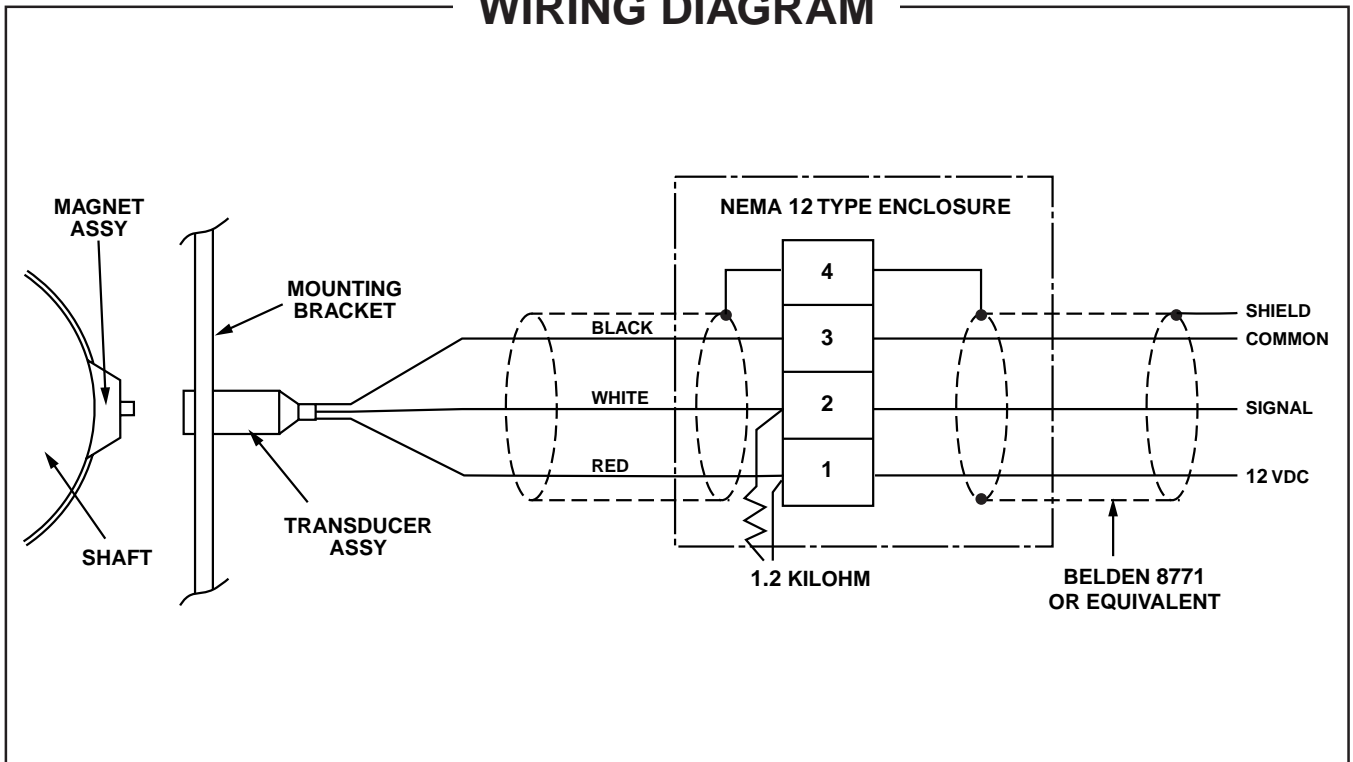

# OUTLINE DRAWING

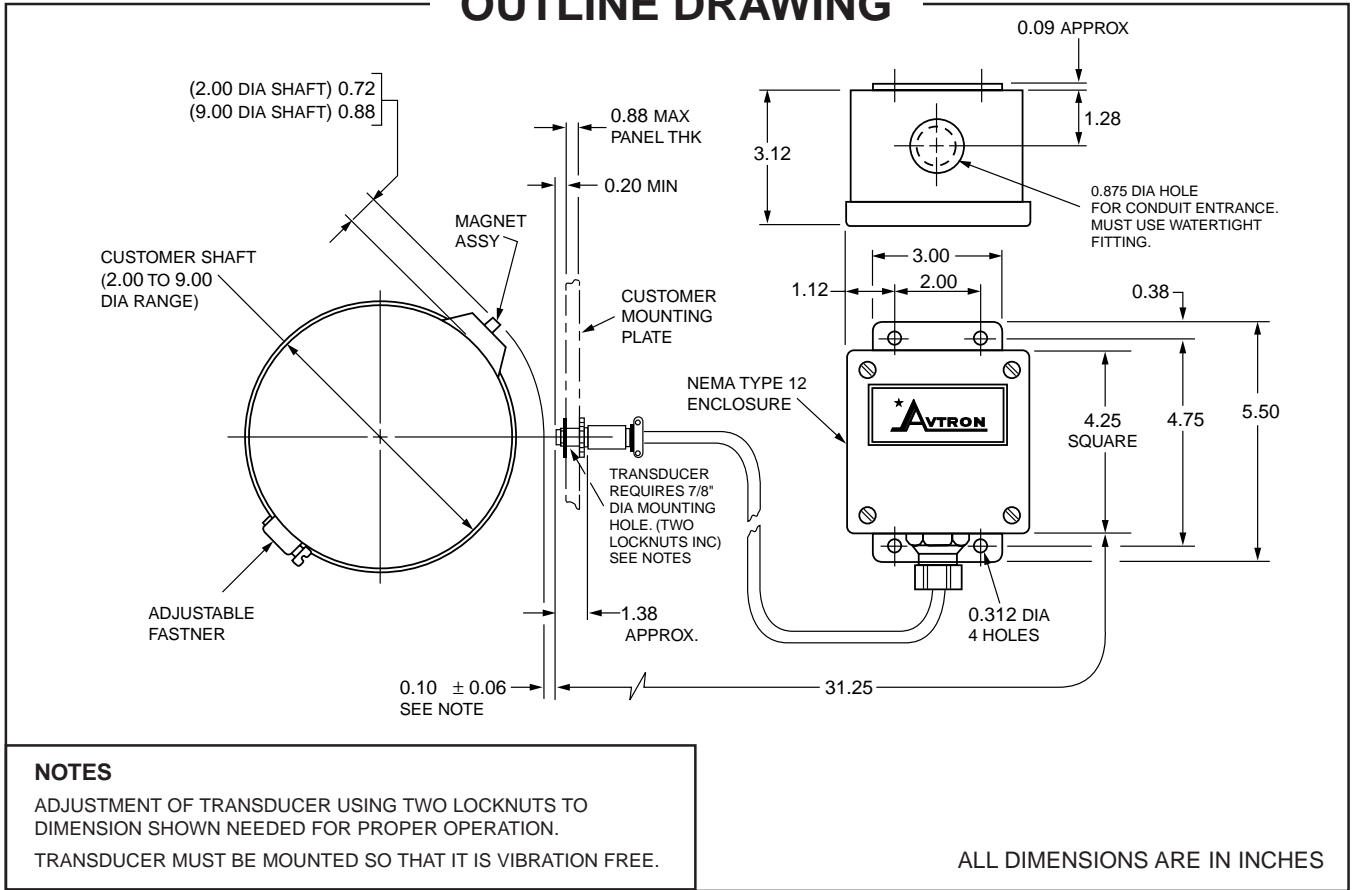

FIGURE 2

## REPLACEMENT PARTS LIST

P/N	DESCRIPTION
B16775	Transducer Assembly
A19404	Magnet Assembly
A17726	Magnet Assembly Kit includes: Magnet Assembly Adjustable Fastener 2-foot Band Material*

\*Band Material up to 100 feet can be ordered separately from Avtron.

