



8901 E. PLEASANT VALLEY ROAD
 INDEPENDENCE, OHIO 44131-5508
 TELEPHONE: (1) 216-642-1230 • FAX: (1) 216-642-6037
 E-MAIL: tachs@avtron.com • WEB: www.avtronencoders.com

Encoder Instructions

M485 SMARTach™

5/8" SOLID SHAFT

DESCRIPTION

The Avtron Model M485 SMARTach™ (patents #5,502,376 and #5,545,985) is a **severe duty** incremental encoder (also known as tachometer or rotary pulse generator). When coupled to a motor or machine, its output is directly proportional to shaft position (pulse count) or speed (pulse rate). The M485 operates down to zero speed and can be used for both control and instrumentation applications.

Mechanically, the M485 mounts on a NEMA 56C adapter flange or it can be foot mounted by using an optional foot mounting bracket kit.

The M485 utilizes magnetoresistive sensors. This proven technology is ideal for rugged environments since it is immune to contaminants that cause optical encoders to fail. These factors, make the M485 ideal for demanding industries like paper, metals, and chemical processing.

An Avtron M485 SMARTach is equipped with one or two M484 sensor modules. Each module has a two-phase output (A, B) 90° out of phase, with complements (A, B̄), (A Quad B Output). A marker pulse with complement (Z, Z̄) is available as an option.

Output resolution is determined by the rotor's base PPR (pulses per revolution), times an M484 sensor multiplier. The M484 sensor module can provide: the base PPR, 1/2 the base PPR, or double the base PPR (see table). With two sensor modules, the same

encoder can provide two different PPRs from a given rotor at the same time. Only one rotor per M485 is possible. Sensors are not interchangeable between M485 units with different base PPRs.

The M484 removable sensor assembly has a diagnostic package that includes Adaptive Electronics and a Fault-Check output.

ADAPTIVE ELECTRONICS

A perfect duty cycle consists of a waveform whose "high" and "low" conditions are of the same duration (50%/50%). It is possible over time for duty cycle to change due to component drift, temperature changes or mechanical wear. The Adaptive Electronics extend the life of the M485 by constantly monitoring and correcting duty cycle over time.

FAULT-CHECK

If the Adaptive Electronics reach their adjustment limit, the Fault-Check alarm and LED will notify the drive and operator of an impending failure. This output occurs **before** a failure, allowing steps to be taken to replace the unit before it causes unscheduled downtime. Fault-Check annunciation is available as an "alarm" output through the connector or as an optional integral LED.

INSTALLATION

Equipment needed for installation

Supplied:

M485 Encoder

Not Supplied:

- Socket Hd. Cap Screw
- 3/8-16 x 0.75 (4)
- Washer, Flat 5/16 (4)
- Washer, Lock 5/16 (4)
- Thread Locker (Loctite 242 recommended)
- 5/16" Hex Wrench (T-Handle style)
- Shaft Coupling
- Motor Adapter Flange
- Dial Indicator

Optional:

Foot Bracket Mounting Kits: A22232 (std) A25448 (BC-42/46)

	AVAILABLE RESOLUTIONS		
	-48 OPTION	-51 OPTION	-60 OPTION
LOW	240	256	300
MEDIUM	480	512	600
HIGH	960	1024	1200

M485 PART NUMBERS AND AVAILABLE OPTIONS (including M484 sensors)

Model	Shaft Options**	Base PPR	Left Module				Right Module			
			Marker	Range (PPR)	Connector	Volts	Marker	Range	Connector	Volts
M485	- Single	48- 480	Z- Marker	X- No left sensor, right sensor only	X- No left sensor	X- No left sensor				
M485L*	D- Dual	51- 512	- None	L- Low Range (Base PPR x 1/2)	M- Wire Leads Only	1- 12-15V	M485/M485L: Same Code Format as Left Module			
M484	G- Shaft	60- 600		M- Medium Range (Base PPR x 1)	L- 10 Pin MS Elbow w/ plug	3- 5-18V	M484/M484L: Not Applicable			
M484L*	Ground			H- High Range (Base PPR x 2)	C- 10 Pin MS w/ plug	5- 5-24V				

* M485L/M484L - Integral LED Alarm Indicator.
 ** Dual and Shaft Ground not applicable on M484/M484L. Refer to separate instructions for additional information on the shaft grounding option.

The removable sensor assemblies included with Model M485 Encoders are identified by model number M484.

An M484 sensor assembly consists of a sensor module and a connector option.

DRIVE INSTALLATION INSTRUCTIONS

The encoder must be driven by a positive drive rather than a friction drive. The following means of coupling are acceptable when properly installed: Direct Coupling, Timing Belt/Pulleys, Chain/Sprockets.

With a direct drive, use a flexible disc coupling and align the shafts as accurately as possible. EXAMPLE: For a size 62 Thomas Miniature Coupling angular misalignment must be less than 1.34°, parallel misalignment less than 0.028", and axial float less than ±0.031". The encoder should not be subjected to any axial thrust. Overhung loads should also be minimized. Installations using timing belts/pulleys should have just enough belt tension to eliminate belt sag. Excessive tension will shorten belt and bearing service life. If a rubber slinger disc is used, position it on the shaft so it will rotate freely.

ELECTRICAL SPECIFICATIONS

		LINE DRIVER/VOLTAGE INPUT OPTIONS		
		1	3	5
INPUT VOLTAGE (+V)		11.5 - 15.5V	4.8 - 18V	4.8 - 26V
LINE DRIVER		4428	4428	7272
START-UP CURRENT NO LOAD		80mA	300mA	300mA
OPERATING CURRENT NO LOAD		80mA	235mA@5V 90mA@12V	235mA@5V 90mA@12V 60mA@24V
DIFFERENTIAL SQUARE WAVE OUTPUT A leads B for CW rotation, anti drive end view	V _{OH}	((+V)-1.8V) min. @50mA avg.	((+V) -1V) min. @50mA avg.	((+V) -2.3V) typ. @20mA avg.
	I _{OH} (Source)	80mA avg. max., 1.5A peak		80mA avg. max.
	V _{OL}	0.6V max. @5V, 0.4V max. @12V @50mA avg.		0.5V max. @20mA avg.
	I _{OL} (Sink)	80mA avg. max., 1.5A peak		80mA avg. max.
MAXIMUM CABLE DRIVE (feet)		2000		1000@5V in. 500@12V in. 200@24V in.
PROTECTION	Reverse Voltage	Yes		Yes
	Transient	Yes		Yes
	Short Circuit	No		Yes
MARKER		Once per revolution. Pulse width approx. 1/3 of base PPR period.		
ALARM Refer to Engineering Note 30	+V (OUT) 50mA max.	This is a convenience output, internally jumpered to +V operating voltage. It is intended for alarm circuits like solid state relays that can be referenced to +V. *		
	ALARM	Open collector, sink 100mA max, withstand 50V max from common. Output goes low on alarm. *		

* (Not available on wiring option "G", Northstar compatible pinout.)

MECHANICAL SPECIFICATIONS

SPEED RANGE	0-4500 RPM for base PPR of 480
SPEED RANGE	0-4200 RPM for base PPR of 512
SPEED RANGE	0-3600 RPM for base PPR of 600
COUPLING RECOMMENDED	Zero backlash, Thomas Miniature Flexible or Equivalent. Where axial endplay exceeds ± 0.020 inch, use Thomas CCX or equivalent.
WEIGHT	11 lbs.

ENVIRONMENTAL SPECIFICATIONS

OPERATING TEMPERATURE	-20°C to 71°C
DUST AND WATER	A standard M485 encoder is shipped with a universal breather/drain to equalize pressure if the tach is exposed to temperature cycles and provide a drain for condensate. The labyrinth design limits the entry of dust and water spray. In environments with stable temperatures, the breather may be replaced with a 1/4" pipe plug making the encoder water-tight and dust-tight.

Features and specifications subject to change without notice.

CAUTION

Do not force or drive the coupling onto the shaft, or damage to the bearings may result. The coupling should slide easily on the shaft. Remove nicks and burrs if necessary. Consider driving shaft endplay when positioning coupling.

For more details on alignment specifications, measurement techniques, and special considerations in specifying and installing drive components, refer to separate installation instructions in the Avtron PULSE GENERATOR HANDBOOK.

NEMA 56C FACE MOUNTING INSTRUCTIONS

- 1) Apply anti-seize compound to inner circumference of coupling (both motor and encoder side).
- 2) Loosen set screws in coupling and apply thread locker to set screws.
- 3) Place coupling on motor shaft, inserting to depth per manufacturer's instructions.
- 4) Attach coupling to motor shaft using set screws per manufacturer's instructions.
- 5) Bolt mounting flange (flowerpot) to motor C-Face, using thread locker with fasteners.
- 6) Slide encoder shaft into other side of coupling. **DO NOT FORCE.** Ensure 1/4" keyway aligns with coupling set screw location.
- 7) Ensure C-Face on mounting flange matches and aligns with encoder C-Face precisely.
- 8) Apply thread locker to hex cap screws.
- 9) Align bolt holes of encoder and flange, thread in (4) hex cap screws, using lock washers.
- 10) Tighten set screws on encoder side of coupling.

FOOT MOUNTING INSTRUCTIONS

Equipment needed for installation

Supplied:

- | | |
|---|--------------------------|
| 1. Foot Bracket (A22232/A25448) | 4. Nut, Hex 5/16-18 (4) |
| 2. Soc. Hd. Cap Screw 3/8-16 x .75 (4) | 5. Washer, Flat 5/16 (4) |
| 3. Hex Hd. Cap Screw 5/16-18 x 1.50 (4) | 6. Washer, Lock 5/16 (4) |
| | 7. Thread Locker (blue) |

Not Supplied:

- 1/2" Wrench
- 5/16" Hex Wrench (T-Handle style)
- Dial Indicator

The NEMA 56C face is the preferred mounting method for the M485. In certain cases, however, it may be necessary to foot-mount this unit. The optional foot mounting bracket kit, Avtron part number A22232, will be required for standard installations or replacement of Northstar RIM6200 units. To replace BC42 or BC46 units, use A25448 foot mount kit. Read all of the following instructions and the Avtron PULSE GENERATOR HANDBOOK prior to beginning any work.

The M485 performance and life will be directly affected by the installation. Following this sequence of steps is recommended.

- 1) Clean and inspect motor/driver shaft. Do not use force to assemble coupling onto motor/driver shaft. The foot mounting bracket must be secured to a flat, rigid, vibration free steel or aluminum base which can be machined to accept 5/16-18 mounting hardware. Clearance will be required for the breather/drain. See next section.
- 2) Temporarily mount the M485 to the foot bracket, install the coupling to the M485 and driver, and verify that the location is suitable for installation.
- 3) If the M485 encoder, bracket and coupling are suited to the area, check motor/encoder shaft alignment with a straight edge from multiple positions around the shaft circumference to verify that it meets specifications.
- 4) While maintaining alignment, precisely mark the position of the foot bracket on its mounting base.

- Remove the M485. Transfer punch or layout the mounting hole pattern as indicated on outline drawing.
- Machine four, 3/8" dia through holes or tap four, 5/16-18 holes in center of base slots to give some degree of freedom in final alignment.
- Reinstall the M485 with the flexible coupling loosely in place, and tighten down all mounting hardware. Check motor/encoder shaft alignment with a straight edge from multiple positions around the shaft circumference to verify that it meets specifications. Use thread locker supplied on cap screws which mount M485 to foot bracket.
- Ensure any flat or keyway on the motor and encoder shaft are aligned with the set screw holes of the flexible coupling. Apply thread locker to coupling set screws and tighten per manufacturer's recommendations.
- Recheck alignment and tighten all hardware after first several hours of operation.

MINIMIZE DOWN-TIME: Should M485 replacement be required, leave the foot mounting bracket installed on its base and mount the new M485 to the bracket. This maintains the original alignment.

BREATHER/DRAIN CONSIDERATIONS

The encoder is shipped standard with a universal breather/drain in the bottom port and a stainless steel pipe plug in the top port. See Environmental Specifications. The breather must be at the lowest point of the tach and have a clear, unrestricted drainage path. If some object interferes with the breather, first try to modify that object. If clearance cannot be provided, the breather may be removed, but only if at least one of the following conditions is met:

- The opening is protected from direct contact with standing or splashing liquids.
- If temperatures will be stable (within 20° C), the breather may be replaced with a 1/4" pipe plug.
- If neither of the above is possible, i.e. the opening must be plugged for protection and temperatures will vary, then the unit should be purged with clean, low-pressure, filtered, positive air

pressure (<5 psi) through the top opening. Do not remove the top plug except to provide such purging. Purging of the M485 should be reviewed with Avtron.

WIRING INSTRUCTIONS

For bidirectional operation of the 2-phase SMARTach, proper phasing of the two output channels is important. Phase A channel leads Phase B channel for clockwise shaft rotation as viewed from the anti-drive or accessory end of the motor (M485 mounting end).

Wiring option "G" provides a pinout compatible with Northstar encoders, with a cable shield connection on pin 10. Note that this option does not ground the shield; Avtron still recommends grounding the shield at the drive end of the cable for all wiring options.

CORRECTIVE ACTION FOR PHASE REVERSAL

- Remove Power.**
- Exchange wires on cable, either at encoder cable end, or at speed controller end (but not both).
 - Single Ended 2 Phase Wiring** (see wiring diagram)
Exchange A and B at the use end of the wires.
 - Differential 2 Phase Wiring** (see wiring diagram)
Exchange **either** A with \bar{A} in the phase A pair **OR** B with \bar{B} in the phase B pair but **NOT** both.
- Apply Power.
- Verify encoder feedback is correct, using hand rotation of shaft, or jog mode of the speed controller.

Interconnecting cables specified in the wire selection chart below are based on typical applications. Refer to the system drawing for specific cable requirements where applicable.

Physical properties of cable such as abrasion, temperature, tensile strength, solvents, etc., are dictated by the specific application. General electrical requirements are: stranded copper, 22 thru 16 gauge (Industrial EPIC options can use 14 AWG), each wire pair individually shielded with braid or foil with drain wire, 0.05 uF maximum total mutual or direct capacitance, outer sheath insulator, 1,000 ft. max. See Wire Selection Chart below for some suggested cables.

WIRING DIAGRAMS

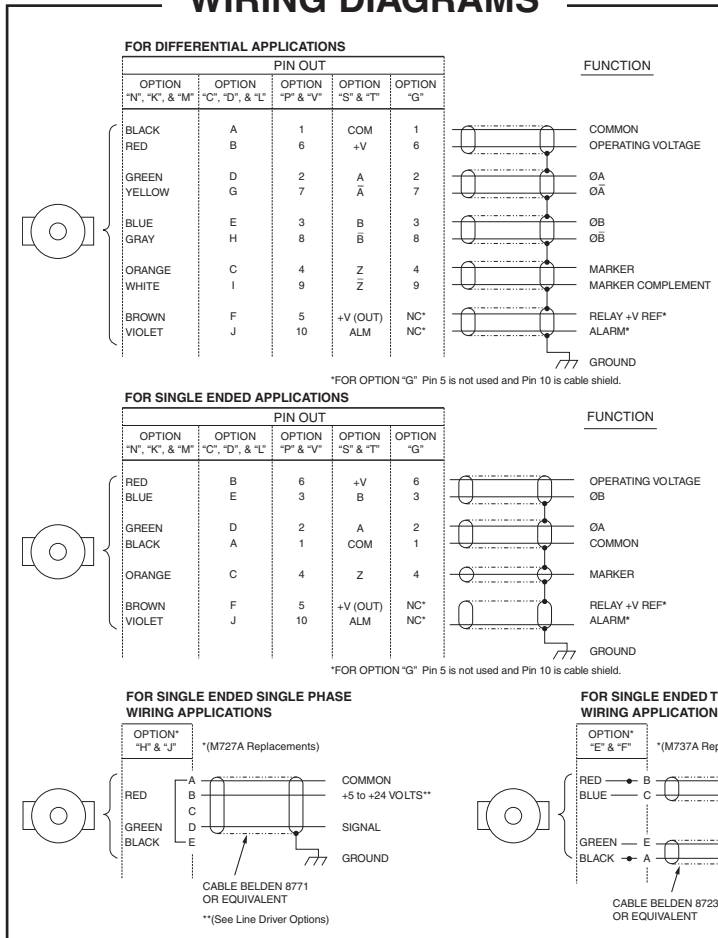

NOTE

When using the plug-in industrial EPIC connector ("G", "P", "V", "X", or "Z" options), the wire ends must be tinned with solder before connection at the screw terminals.

NOTES: Marker output for connector options "E" & "F" - Pin "D"
Marker output for connector options "H" & "J" - Pin "C"

TYPICAL WIRE SELECTION CHART
for 18 AWG, multiple pair, individually shielded

	BELDEN	ALPHA
2 PAIR	9368	6062
3 PAIR	9369	6063
4 PAIR	9388	6064
6 PAIR	9389	6066

OUTLINE DIMENSIONS AND OPTION DETAILS

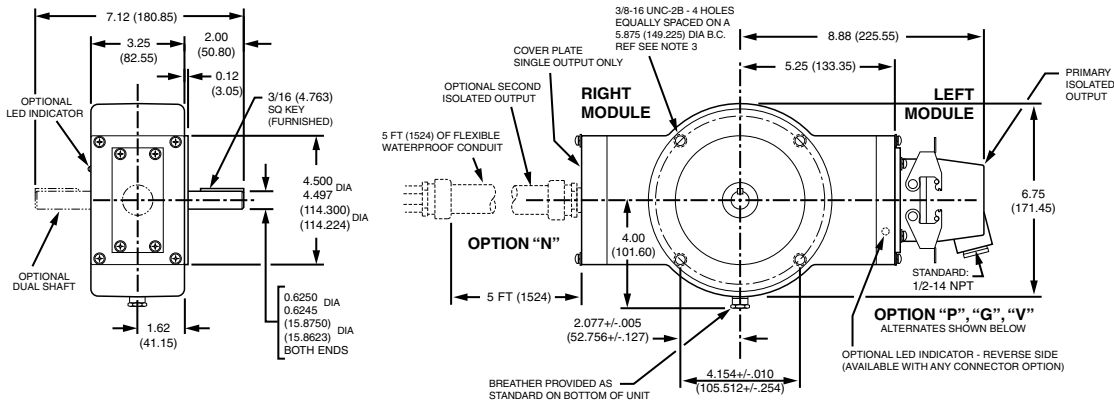

M485 PULSE GENERATOR

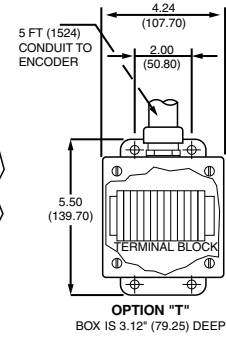
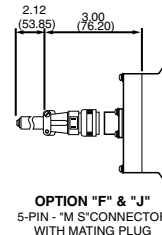
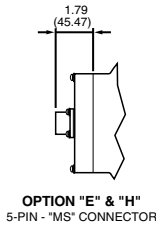
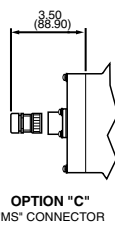
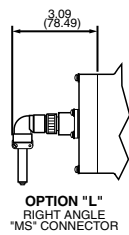
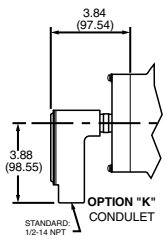

OPTIONAL FOOT BRACKET

INCLUDES ALL HARDWARE NECESSARY FOR MOUNTING ENCODER AND FOOT BRACKET TO MACHINE BASE.

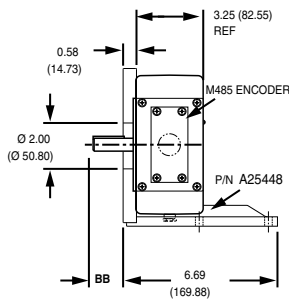
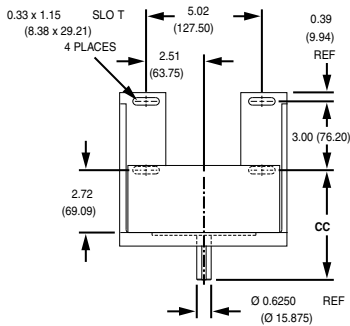
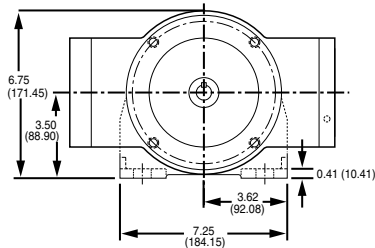
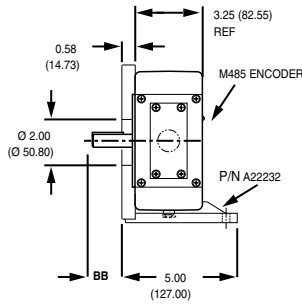
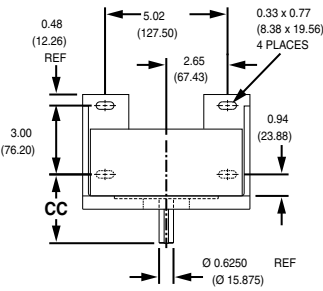

Foot Mount Bracket	Bolt Pattern	BB	CC
A22232	Std./RIM6200	1.42 (36.07)	3.00 (76.20)
A25448	BC-42/46	2.00 (36.07)	4.78 (121.41)

NOTES:

1. Dimensions are in inches except as noted.
2. All dimensions are approximate.
3. Pilot mounting conforms to a NEMA 56C face.
4. Dimensions in parenthesis are in millimeters.

EU Declaration of Conformity: The Model M485 SMARTach Encoder has been assessed and type tested against the following Harmonized European Standards: EN 50081-1:1992, EN 50082-1:1998. The Model M485 has been found to be compliant with the requirements of EU Directive 89/336/EEC provided that the following conditions are met: The electrical supply to the M485 must be within specified limits. The electrical supply must offer suitable protection from voltage surges unless the application does not require such protection. On behalf of Avtron Manufacturing: Stephen L D'Henin, Certification Manager, Epsilon Certification Service.

Features and specifications subject to change without notice. Avtron standard warranty applies. All dimensions are in inches (mm).



8901 E. PLEASANT VALLEY RD., INDEPENDENCE, OH 44131, U.S.A. • (1) 216-642-1230 • FAX (1) 216-642-6037 • www.avtronencoders.com



REV: 02-23-07