



8901 E. PLEASANT VALLEY ROAD
 INDEPENDENCE, OHIO 44131-5508
TELEPHONE: (1) 216-642-1230 • **FAX:** (1) 216-642-6037
E-MAIL: tachs@avtron.com • **WEB:** www.avtronencoders.com

Encoder Instructions

M7-4 & M7-5

HOLLOW SHAFT

DESCRIPTION

The Avtron Model M7-4 and M7-5 are Hollow Shaft Incremental Encoders (also known as tachometers or pulse generators). They are similar to the model M6 flameproof rotary hollow shaft incremental encoders but offer extended temperature range from -45C to +80C. M7 encoders require external heater power (0.77A @ 24V) to operate below -40C.

When mounted to a motor or machine, the M7 output is directly proportional to shaft position (pulse count) or speed (pulse rate). The M7 can be used for both control and instrumentation applications. The hollow shaft version of the model M7 eliminates shaft couplings, adapter flanges, and accessory mounting faces. The unit employs a hollow shaft and clamping collar to lock the encoder to the shaft. An anti-rotation bracket prevents rotation of the encoder while allowing for shaft end float.

The enclosures on all Model M7's are rated IP66 to protect the internal components from the entry of dust and water. Additionally, the M7 uses magnetoresistive sensing technology, making the M7 ideal for demanding industrial environments.

All M7s can be equipped with one or two outputs. Each output is electrically independent and totally isolated.

The outputs can be wired as single ended single phase, single ended two phase (A,B), or differential (A Quad B). Output resolution is determined by the rotor's base PPR (pulses per revolution), times a sensor multiplier. The sensor module can provide: 1/2 the base PPR, the base PPR, or double the base PPR (see table). With two outputs, the same encoder can provide two different PPRs from a given rotor at the same time. Only one rotor per encoder is possible.

Example: an M7 could use a 1024 PPR sensor output on one side for feedback to a drive system, and simultaneously use a 256 PPR sensor on the other side for a process computer.

	AVAILABLE RESOLUTIONS		
	-48 OPTION	-51 OPTION	-60 OPTION
LOW	240	256	300
MEDIUM	480	512	600
HIGH	960	1024	1200

INSTALLATION CONSIDERATIONS

The M7 standard anti-rotation arm will tolerate ± 2" of shaft end float. Consideration should be taken when positioning the encoder.

The M7 must be properly oriented for operation below -40C. Be sure the encoder is mounted horizontally, and with the label marked "This side up" at the top. The ground lug should be at the bottom of the encoder.

CAUTION

Be careful not to damage clamping fingers during handling. Do not tighten clamping collar before installation onto motor shaft. Damaging clamping fingers can affect the quality of installation.

M7 ENVIRONMENT

The M7 is not considered as a safety device and is not suitable for connection into a safety system.

For operation below -40C, the M7 must be allowed to warm up for at least one hour before rotation. Failure to allow warm-up may cause encoder malfunction or failure.

INSTALLATION

Equipment needed for installation

Supplied:

- | | |
|------------------------------------|----------------------------------|
| 1. M7 | 7. Nut, 1/4-20 |
| 2. Clamping Collar | 8. Washer, Flat 1/4 (2) |
| 3. Anti-rotation Bracket | 9. Washer, Lock, 1/4 |
| 4. Thread Locker (blue) | 10. Washer, Shoulder, Insulating |
| 5. Screw, Button Hd., 3/8-16 x .50 | 11. Washer, Flat, Insulating (2) |
| 6. Screw, Socket cap 1/4-20 x .62 | 12. Anti-seize (copper) |

Not Supplied:

- 7/32" Hex wrench (T-handle style)
- 3/16" Hex wrench (T-handle style)

Clean machine shaft of any dirt and check for any burrs or damage.

The hollow shaft M7 is intended to be installed with a torsionally rigid flexible anti-rotation arm. See specifications for maximum shaft and bearing load ratings. The encoder should not be rigidly mounted.

M7 PART NUMBERS AND AVAILABLE OPTIONS								
Model	Bore Size	Mounting Style	Line Driver	Left & Right Output Range	Base PPR	Marker	Connector	Modifications
M7-	0- Non-Standard 4- 1" 5- 1 1/8"	S- End-of-shaft	3- 12 to 24 VDC*	X- None L- Low Range (Base PPR x 1/2) M- Medium Range (Base PPR x 1) H- High Range (Base PPR x 2)	48- 480 51- 512 60- 600	Z- Marker -- None	T- Conduit Box, Terminal Block, 3/4" NPT W- Conduit Box, Terminal Block and Wire Gland	000- None

* Units shipped prior to 2009 were rated 18 to 24 volts. Refer to ID tag on the encoder for specific input voltage requirements.

Instructions for Installation of the Standard Threaded Rod Anti-Rotation Tether:

Install the anti-rotation bracket to the motor side of the M7 using two 3/8-16 screws and thread locker.

Remove screws from clamping collar, apply anti-seize compound supplied to the inside of the collar and thread locker supplied to the threads and reinstall. Place clamping collar loosely on the inboard end of the shaft. **Carefully** slide M7 onto the shaft. **DO NOT FORCE**. Encoder should slide on easily. After verifying M7 fit onto shaft, remove M7, apply anti-seize compound (supplied) to shaft and re-install M7 (see shaft engagement). Tighten screws on clamping collar evenly until snug, then firmly tighten. **DO NOT USE A STANDARD RIGHT ANGLE WRENCH**. Use only a T-handle hex wrench or torque wrench with hex bit. See the diagram on page 4 for complete assembly instructions.

Secure free end anti-rotation bracket to frame. Use supplied insulating hardware if necessary as shown. Adapter kits are available for NEMA 56C and 8 1/2" mounting faces.

Shaft Engagement For End-of-Shaft Mounting Applications:

See table on last page.

For shaft lengths greater than the maximum engagement allowed, end-of-shaft mounting may still be employed by locating the encoder away from the motor using a spacer between the motor and anti-rotation bracket. Although the tether arm permits pivoting to allow motor shaft movement, the arm should be straight and parallel to the encoder face when installed.

Corrective Action for Excess Housing Movement (Wobble)

The hollow shaft M7 design eliminates the potential for bearing and coupling failures from misalignment. However, excessive housing movement (wobble) may cause undesirable vibrations. The higher the RPM, the more severe the vibration will be from housing movement. In a typical installation, a housing movement

of 0.007" TIR or less (as measured at the outside diameter of the main encoder body) will not have an adverse effect. If excessive housing movement is detected in the installation:

1. Check the shaft the M7 is mounted on for excessive shaft runout. NEMA MG1 calls for 0.002" TIR or less.
2. Verify that the M7 engagement with the motor shaft conforms to the engagement rules on page 4. In general, maximizing engagement will minimize housing movement.
3. Verify that the mounting shaft diameters conform to the rules on page 4. Excessive housing movement occurs when the clearance between the motor shaft and pulse generator shaft allows the two center lines to miss match.
4. Loosen the clamping collar and rotate the motor shaft 180° within the M7 hollow shaft sleeve.
5. Make sure the clamping collar is tightened equally on both sides.
6. Move the split in the clamping collar over a solid portion of the M7 shaft.

If excessive housing movement still exists after the above steps, it may be necessary to physically bias the attitude of the encoder on the motor shaft while the clamping collar is being tightened. Either by eye or using dial indicators, note the position around the outside diameter of the encoder that is most out of position from true while turning the motor shaft slowly. With the motor shaft no longer turning, loosen the clamping collar. While applying moderate force by hand against the outside diameter of the encoder on the side opposite where the out of true position was observed, retighten the clamping collar. Several iterations may be necessary if the first attempt under or over compensates. This method may be used to help compensate for undersized shafts, shaft runout, bent clamping fingers, and other problems.

WIRING INSTRUCTIONS

The M7 can be wired for single phase, two-phase, with or without complements, with or without markers. See wiring diagrams on page 3.

SPECIFICATIONS

ELECTRICAL

- A. Operating Power (Vin)
 1. Volts..... 12-24 VDC
 2. Current..... 120mA per output, no load
 3. Heater..... 24V 770mA Power required for operation below -40°C
- B. Output Format
 1. 2Ø & Comp (A, \bar{A} , B, \bar{B})
 2. Marker..... 1/Rev (Z, \bar{Z})
- C. Signal Type..... Incremental, Square Wave, 50 ±10% Duty Cycle
- D. Direction Sensing..... ØA leads ØB for CW rotation as viewed from the back of the tach looking at the non-drive end of the motor.
- E. Transition Sep..... 15% minimum
- F. Frequency Range..... 0 to 150,000 Hz.
- G. PPR..... 240, 256, 300, 480, 512, 600, 960, 1024, 1200
- H. See Line Driver Options

MECHANICAL

- A. Shaft Inertia..... 0.8 to .23 oz. In. sec.²
- B. Acceleration..... 5,000 RPM/Sec. Maximum
- C. Starting Torque..... 1.5 to 20 Oz. In.
- D. Speed..... 5,000 RPM Max. (M7-4, -5)
- E. Weight..... 16-18 lbs.
- F. Shaft Diameter
 - Tolerance..... See drawing on page 4.
- G. Shaft Engagement..... See drawing on page 4.
- H. Bearing Protection: Shaft seal & double bearing seal.
- I. Bearing Life with No Additional Loading: 6.1 x 10⁹ Revolutions
- J. Maximum Additional Bearing Load:
 - 4 & -5 (1" & 1 1/8"): 10 pounds axial or 30 pounds radial
- K. Shaft Material: Black Oxide treated steel.
- L. Housing Material: Cast aluminum with Polane S Plus polyurethane enamel finish.

ENVIRONMENTAL

- A. Enclosure Rating: IP66
- B. Operating Temperature: -45°C to 80°C
- ** -40°C Standard

OUTPUT TERMINATIONS

Terminal Block: C compression type. Accepts AWG 14 (2.08mm²) to AWG 20 (.52mm²) stranded wire. Housing available with 3/4 NPT or optional armored cable gland available (maximum ambient temperature with gland +60°C allowing for 20°C rise in housing.)

LINE DRIVER OPTIONS

Output Options	
	3*
Voltage Input (Vin)	12-24 VDC
Output High	330 ohm pull up
Output High (milliamps)	330 ohm pull up
Output Low (Volts)	1 (max.)
Output Low (milliamps)	50 (avg.)
Protection	Reverse Voltage, Transient, Short Circuit (low)
Maximum Cable Drive(Feet)	1000 ft.

* Units shipped prior to 2009 were rated 18 to 24 volts. Refer to ID tag on the encoder for specific input voltage requirements.

CAUTION

Do not wire the M7 Encoder while energized.

For bidirectional operation of the encoder, proper phasing of the two output channels is important. Phase A channel leads phase B channel for clockwise shaft rotation as viewed from the anti-drive or accessory end of the motor (M7 mounting end).

CORRECTIVE ACTION FOR PHASE REVERSAL

- 1) **Remove Power.**
- 2) Exchange wires on cable either at encoder cable end or at speed controller end (but not both).
 - a) **Single Ended 2 Phase Wiring** (see wiring diagram)
Exchange A and B at the use end of the wires.
 - b) **Differential 2 Phase Wiring** (see wiring diagram)
Exchange **either** A with \bar{A} in the phase A pair **OR** B with \bar{B} in the phase B pair but **NOT** both.
- 3) Apply Power.
- 4) Verify encoder feedback is correct, using hand rotation of shaft, or jog mode of the speed controller.

Refer to the system drawing for specific cable requirements where applicable.

Physical properties of cable such as abrasion, tensile strength, solvents, marine applications, etc., are dictated by the specific application. Requirements for hazardous locations are dictated by the relevant codes. General electrical requirements are: stranded copper, 20 AWG (.52mm²) thru 14 AWG (2.08mm²) each wire pair individually shielded with braid or foil with drain wire, 0.05 uF maximum total mutual or direct capacitance, outer sheath insulator, 2,000 ft. max. (see line driver specifications.) Temperature ratings of wire and wire glands should be 20°C over the maximum expected ambient or motor temperature to allow for temperature rise in the M7 itself.

MAINTENANCE

CAUTION

Do not open the M7 housing. There are no user serviceable parts inside and the warranty will be voided.

Build up of large amounts of contamination are to be avoided. Therefore, periodic external cleaning is recommended.

WIRING DIAGRAMS

DIFFERENTIAL APPLICATIONS

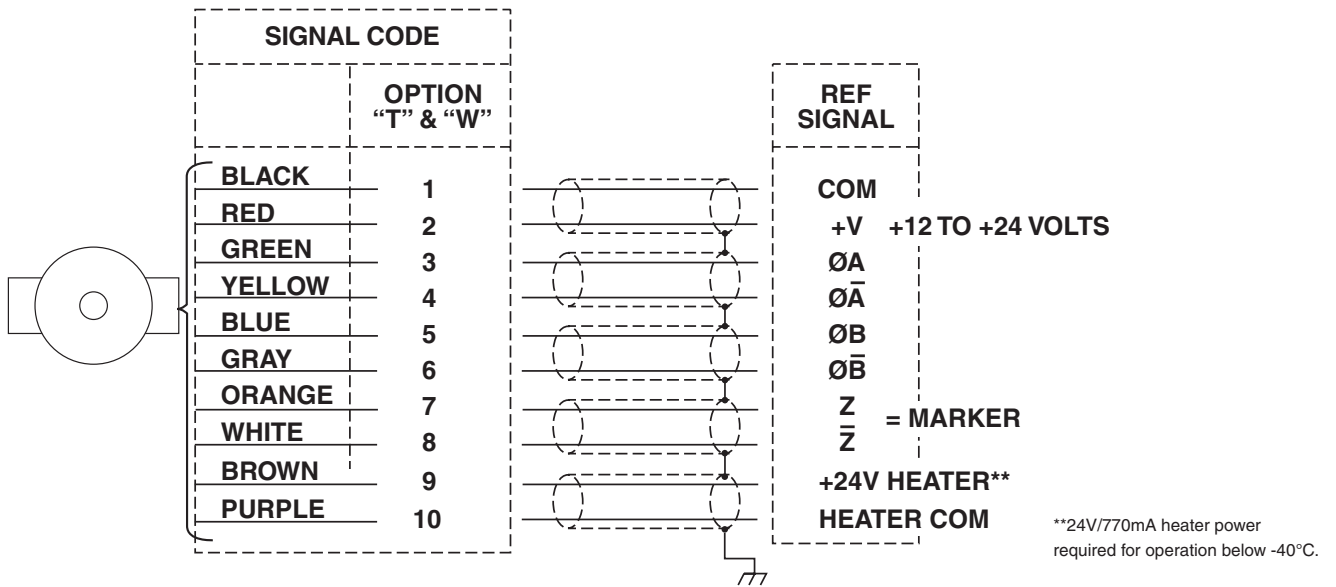

SINGLE ENDED SINGLE PHASE APPLICATIONS

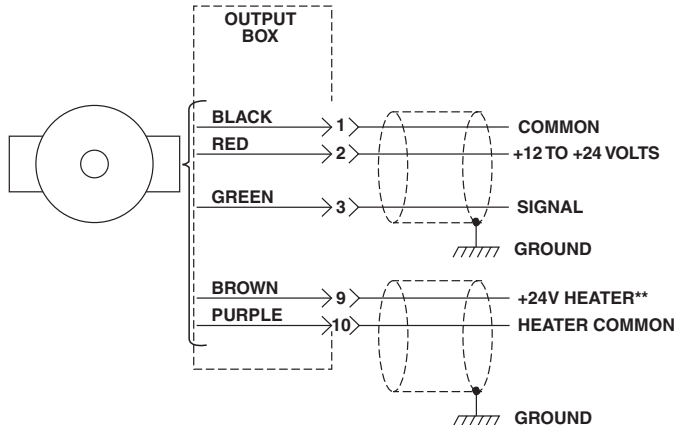

SINGLE ENDED TWO PHASE APPLICATIONS

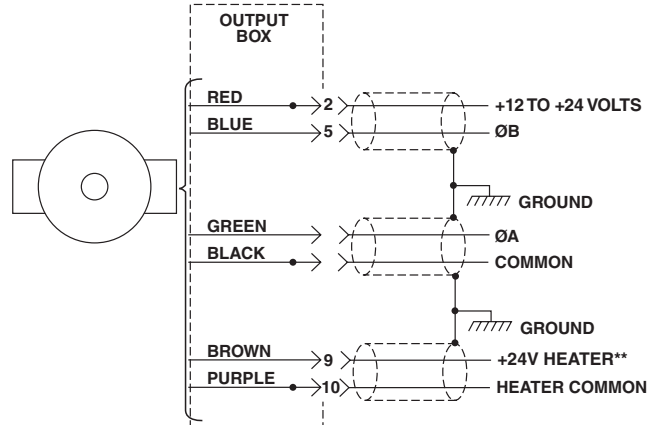

NOTE: Avtron standard warranty applies. Copies available upon request. Specifications subject to change without notice.

TYPICAL WIRE:
18 AWG (.82mm²), multiple pair, individually shielded.

OUTLINE DRAWING

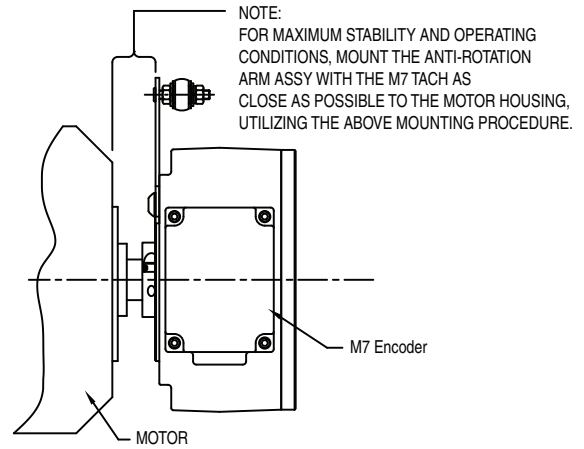
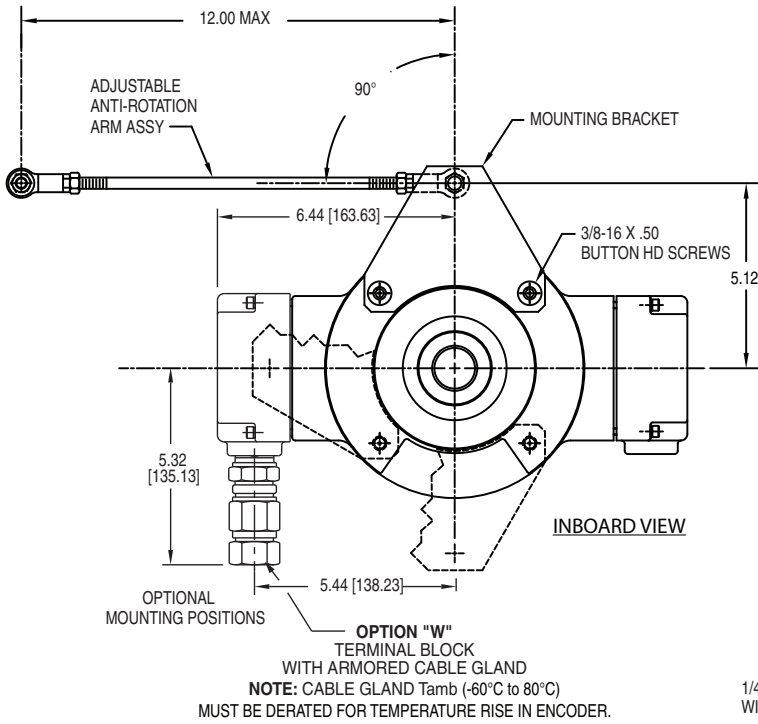

MOUNTING PROCEDURE:

1. FASTEN THE MOUNTING BRACKET TO THE INBOARD SIDE OF THE M5/M6/M7 IN ONE OF THE POSITIONS SHOWN. USE THE TWO 3/8-16 X .50 LONG FASTENERS AND THREADLOCKER.
2. MOUNT THE ANTI-ROTATION ARM PERPENDICULAR TO MOTOR SHAFT AXIS OF ROTATION. THE ARM MOUNTING BOLTS AND ASSOCIATED ROD BEARINGS SHOULD BE PARALLEL TO THE MOTOR SHAFT (TOP VIEW).
3. MOUNT ANTI-ROTATION ARM APPROXIMATELY 90° TO A LINE ESTABLISHED BETWEEN THE MOUNTING BRACKET STUD AND SHAFT CENTERLINE (VIEWED FROM END).
4. MOUNT M7 AS CLOSE AS POSSIBLE TO THE MOTOR WITH THE MOUNTING BRACKET CLOSEST TO THE MOTOR. BE SURE THE LABEL MARKED "THIS SIDE UP" IS AT THE TOP.
5. ESTABLISH A STATIONARY (STATIC) MOUNTING POINT FOR THE FREE END OF THE ANTI-ROTATION ARM USING THE GUIDELINES ABOVE. USE THE 5/16-24 X 1.25" BOLT TO FASTEN THE FREE END TO THE STATIONARY POINT.
6. THE ANTI-ROTATION ARM IS FULLY THREADED AND CAN BE CUT TO LENGTH. THE RECOMMENDED LENGTH IS 8 TO 12 INCHES.

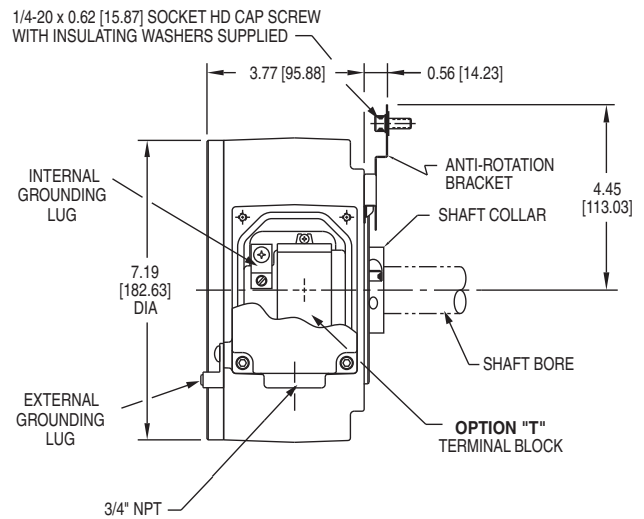

SHAFT OPTION	DIMENSION		
	AA MOTOR SHAFT OD	BB LENGTH	CC MIN/MAX ENGAGEMENT
4	1.0000/0.9995 [25.4000/25.3873]	4.30 [109.22]	2.000/2.620 [50.800/66.548]
5	1.1250/1.1245 [28.5750/28.5623]	4.30 [109.22]	2.000/2.620 [50.800/66.548]

Features and specifications subject to change without notice. Avtron standard warranty applies. All dimensions are in inches [mm] approx.

