



8901 E. PLEASANT VALLEY ROAD
 INDEPENDENCE, OHIO 44131-5508
TELEPHONE: (1) 216-642-1230 • **FAX:** (1) 216-642-6037
E-MAIL: tachs@avtron.com • **WEB:** www.avtronencoders.com

Encoder Instructions

MODEL M85

8 1/2" C-FACE MOUNT
 MODULAR

DESCRIPTION

The Avtron M85 is a modular, two piece incremental encoder (also known as tachometer or rotary pulse generator). It provides a two phase, A Quad B frequency (pulse) output, with complements. The M85 mounts on a 8.5" C-Face, also known as a 180 C-Face or an FC-Face.

Because the M85 is modular, there are no bearings or couplings required. This, combined with the latest magneto-resistive (MR) sensor technology, allows the M85 to provide superior mechanical performance and increased reliability.

An Avtron M85 can be configured with one or two independent outputs. Each output has six signals: (A, B) 90° out of phase, with complements (Ā, B̄). A marker pulse with complement (Z, Z̄) is also provided.

INSTALLATION

Refer to the back page of these instructions for outline and mounting dimensions. The motor must comply with 1998 NEMA MG 1, section 4, for tolerances on diameters and runout for shafts and accessory faces. Axial float or end-play must be less than ±0.050".

In preparation for installing the Model M85 encoder, it is first necessary to clean both the accessory motor shaft and the mounting face. These surfaces must be inspected and paint, burrs, and other surface imperfections removed.

Installation procedures should be performed only by qualified personnel. Safety precautions must be taken to ensure machinery cannot rotate and all sources of power are removed during installation.

Equipment Needed for Installation

Provided	Optional	Not Provided
M85 Stator/Housing Socket Hd Cap Screw 1/2"-13 x 1.50" (4)	Extended Shaft Cover with Screws #6-32 x 0.31" (4), lock washers	Phillips Screwdriver 5/64" Hex Wrench (T-Handle Style for Std. Thru-Shaft Rotors)
M85 Rotor Socket Set Screw #8-32 x 0.19" (2) or End-of-Shaft Rotor Hardware Installation Kit or Pre-Installed Cam Screws	Thru Shaft Cover w/ V-Ring Seal and Silicone Lubricant	1/8" Hex Wrench (T-Handle Style for Cam Screw Rotors)
Rotor Locator Gauge		3/8" Hex Wrench (T-Handle Style for Stator/Housing)
Thread Locker (blue)		End-of-Shaft ONLY
Anti-Seize Compound (copper)		5/32" Hex Wrench 5/16" Hex Wrench 9/16" Wrench

STANDARD THRU SHAFT ROTOR INSTALLATION

The motor shaft must project at least 0.63" from the motor face. Apply anti-seize compound to the motor shaft. Apply thread locker to the rotor set screw holes, preferably from the inside of the bore. Slide the rotor onto the shaft with the P/N marking facing out (away from the motor face). The rotor centerline must match the sensor centerline. To accomplish this, use the Rotor Locating Gauge and slide the rotor onto the shaft until it is in the proper position as shown in Figure 1. Tighten the rotor set screws to 15 in-lb using the 5/64" T-handle hex wrench.

Model	Housing Type	Shaft Size		Cover Style	Line Driver	Single/Left Output	Right Output	Connector	Modifications
		Thru Shaft	End of Shaft						
M85-	1- Single Output, 8.500" Pilot 2- Dual Output, 8.500" Pilot	0- None 1- 10mm L- 1.875 2- 12mm M- 2.000 3- 0.500 N- 2.125 4- 0.625 Q- 2.250 5- 0.875 P- 2.375 6- 0.938 R- 2.500 7- 1.000 S- 2.625 8- 1.125 T- 70mm* 9- 1.250 U- 2.875 10- 1.375 V- 3.000* 11- 1.500 4- 3.125* 12- 1.625 7- 3.188* 13- 1.750 6- 85mm*	W- CD180-32x X- CD36x Y- CD4xx Z- CD5xx	X- None E- Extended Shaft Cover F- Flat Cover T- Flat Thru-Hole Cover with Shaft Seal	1- 5 to 24 VDC 2- 5 to 15 VDC 4- 5 to 24 VDC, 5v out	A- 128 PPR B- 256 PPR C- 512 PPR D- 1024 PPR E- 2048 PPR F- 120 PPR G- 240 PPR H- 480 PPR I- 960 PPR L- 600 PPR M- 1200 PPR	X- None A- 128 PPR B- 256 PPR C- 512 PPR D- 1024 PPR E- 2048 PPR F- 120 PPR G- 240 PPR H- 480 PPR I- 960 PPR L- 600 PPR M- 1200 PPR	P- 10 Pin EPIC Ind. w/ Plug Q- 18" Flex. Cable w/ Ind. Connector w/ Plug & w/ Adapter Block W- 3 Ft. Flex. Cable, Sealed Z- 3 Ft. Flex. Cable w/ EPIC Industrial	000- No Modification 001- Baldor DC400 Adapter~ 002- Baldor DC500 Adapter~ 004- Drain Hole (single output only) 006- Right Angle Cable Bushing 009- No Paint 010- Cam Screw Rotor 013- Cam Screw 150°C Rotor* 9xx- Special Cable Length, xx=length in feet

* Cam Screw Rotors US sizes only, 2.875" max.
 ~ Use with "W" option only

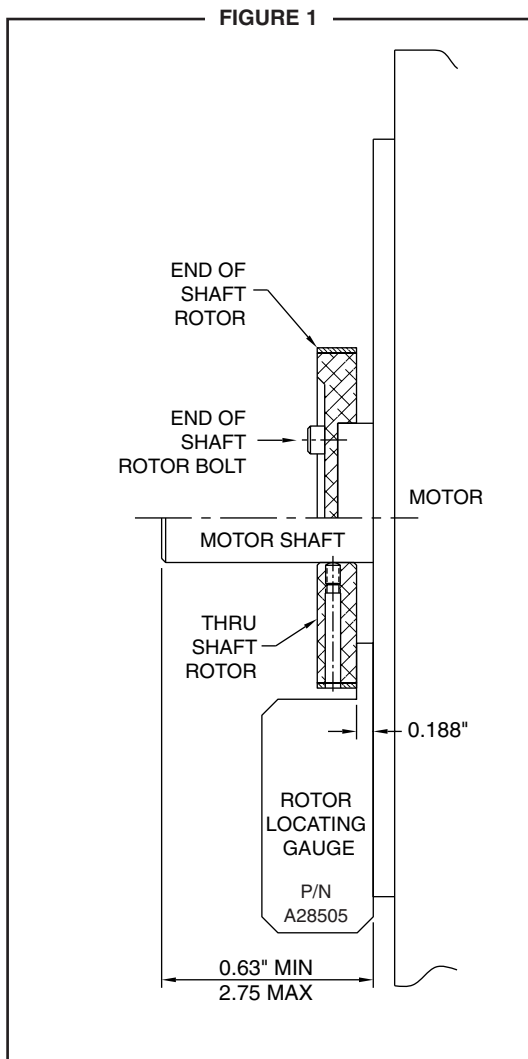

CAUTION

Use only a T-handle or torque hex wrench to tighten set screws; using a right angle wrench will not provide enough holding force, and the rotor may slip.

CAM SCREW ROTOR INSTALLATION

(Modification option 010)

For high slew rate applications where the motor is accelerating and/or decelerating often, Avtron offers an optional Cam Screw rotor. To install the Cam Screw rotor, apply anti-seize compound to the motor shaft, then slide the rotor onto the shaft until it is in the proper position as indicated by the Rotor Locating Gauge (Figure 1). Tighten the locking cam screws in the direction indicated next to the screw (cw/ccw) using 4-6 ft-lbs of torque using the 1/8" T-handle hex wrench (Figure 2). To ensure torque on small shafts that turn easily, two 1/8" hex wrenches may be used at the same time, or the finger-holes may be used.

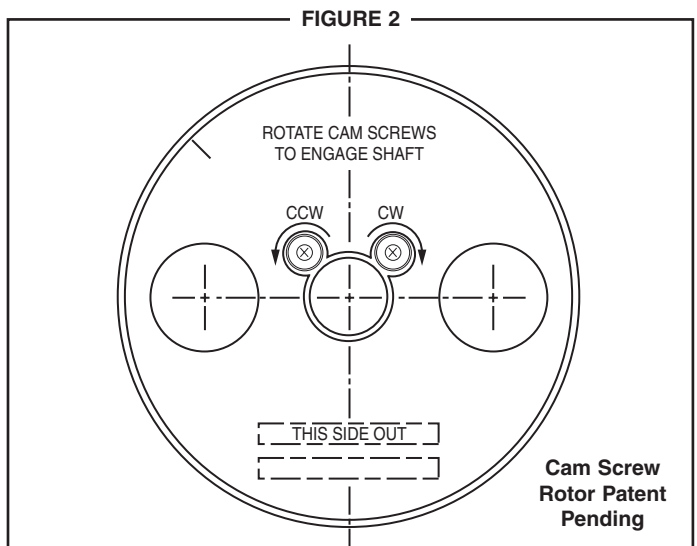

SPECIFICATIONS

ELECTRICAL

- A. Operating Power (Vin) (See Line Driver Options)
 - 1. Volts.....5-24 VDC (option 1 & 4), 5-15 VDC (option 2)
 - 2. Current.....60mA, each output, no load
- B. Output Format
 - 1. 2Ø & CompA,Ā, B,Ē (differential line driver)
 - 2. Marker:.....1/Rev
- C. Signal Type.....Incremental, Square Wave, 50 ±10% Duty Cycle.
- D. Direction Sensing.....ØA leads ØB for CW rotation as viewed from the back of the tach looking at the non-drive end of the motor.
- E. Transition Sep.....15% minimum
- F. Frequency Range:.....0 to 150,000 Hz
- G. PPR.....120-2048
- H. Line Driver Specs:.....See table
- I. Connectors:.....See connector options on page 1

MECHANICAL

- A. Rotor Inertia:0.04 Oz. In. Sec.²
- B. Acceleration:.....5000 RPM/Sec. Max.
- C. Speed:5000 RPM Max.
- D. Weight:2.5 to 4 lbs. [1.13 to 1.81 kg.]
- E. Sensor to Rotor
 - Air Gap (nominal):.....0.030"
 - Tolerance:.....±0.015"

ENVIRONMENTAL

Solid cast aluminum stator and rotor

Fully potted electronics, protected against oil and water spray
Use "W" cable option for IP66/67 applications

V-Ring seals provided on through shaft covers

Operating Temperature:.....-40 to 100°C (150°C rotor optional),
0-100% condensing humidity

LINE DRIVER OPTIONS

	Output Options		
	1	2	4
Voltage Input (Vin)	5-24 VDC	5-15 VDC	5-24 VDC
Output High (Volts)	(Vin) -2 (typ)	(Vin) -1 (typ)	5 VDC
Output High (milliamps)	80 (max.)	80 (avg.), 1500 (peak)	80 (max.)
Output Low (Volts)	0.5 (typ)	0.5 (typ)	0.5 (typ)
Output Low (milliamps)	80 (max.)	80 (avg.), 1500 (peak)	80 (max.)
Protection	Reverse Voltage, Transient, Short Circuit (high & low)	Reverse Voltage, Transient	Reverse Voltage, Transient, Short Circuit (high & low)
Maximum Cable Drive(Feet)	1000 ft. @ 5 V 500 ft. @ 12 V 200 ft. @ 24 V	2000 ft.	1000 ft. @ 5 V

CAUTION

Do not adjust the cam screws before motor shaft mounting; bottoming out the screws, or backing them out excessively, can lead to insufficient shaft holding force. Thread Locker is preapplied on the cam screws.

STANDARD END-OF-SHAFT ROTOR INSTALLATION

(Shaft sizes “W”, “X”, “Y”, and “Z”)

The motor shaft must project 0.40" +/- 0.05" from the motor face including axial end play. Mount the rotors using the hardware supplied. See accompanying chart. On 180 through 320 frame motors, a roll pin is used to prevent rotation of the rotor on the motor shaft. Apply anti-seize compound to the motor shaft. Check that the rotor fits on easily without resistance. The hardware should not be used to force the rotor onto the shaft. Install the pin in the rotor, then position the rotor on the shaft. Lightly tap into place. Install the center bolt and flat washer with springlock washer and tighten. The position of the installed rotor can be verified using the gauge as shown in figure 1, or later, using the housing alignment grooves after housing installation (Figure 3).

STATOR HOUSING INSTALLATION

The stator housing is attached to the motor using four socket head cap screws 1/2"-13 x 1.5" long, locating on a 7.25" bolt circle. Longer bolts, (not included), are required for sandwich installation between a motor and a brake. Install the four mounting bolts using thread locker and torque to approximately 20 to 30 foot pounds using the 5/16" T-handle hex wrench.

VERIFY ROTOR LOCATION

To ensure the rotor is properly located on the shaft: remove the back cover if factory-preinstalled, and verify

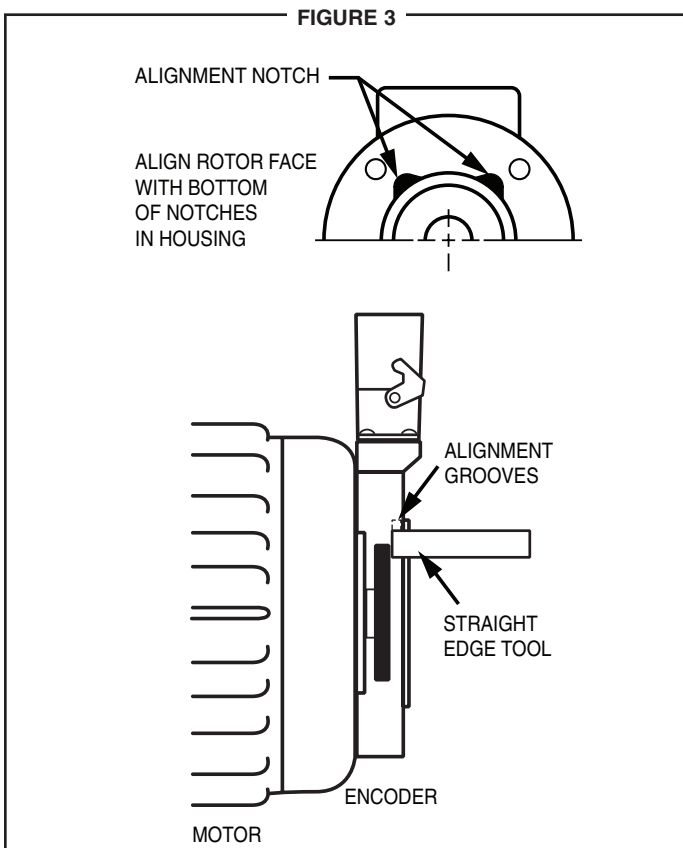

that the outer face of the rotor is at the same depth as the alignment grooves, using a straight edge tool. (Figure 3)

CAUTION

Do not use silicone sealants or caulk of any kind on the motor or encoder face; these can cause misalignment or sensor scraping damage. The M85 electronics are fully sealed; water may enter and leave the rotor area as needed. A drain hole option is available if frequent moisture buildup is expected.

COVER INSTALLATION

Covers must not interfere with the motor shaft or rotor. The longest shaft that can be used without interfering is 0.93" with a flat cover (Cover Style option “F”) and 2.75" with an extended “pie pan” cover (Cover Style option “E”). Through shaft covers with seals are available for “sandwich” style applications (Cover Style option “T”).

EXTENDED COVER MOUNT (Cover Style option “E”)

The extended cover mounts to the encoder housing using quantity 4 #6-32 x 0.31" screws, lock washers, and thread locker.

THRU SHAFT AND FLAT COVER INSTALLATION

(Cover Style options “T” and “F”)

The housing has a machined step in the outboard face to accept the cover and a recessed groove for the retaining

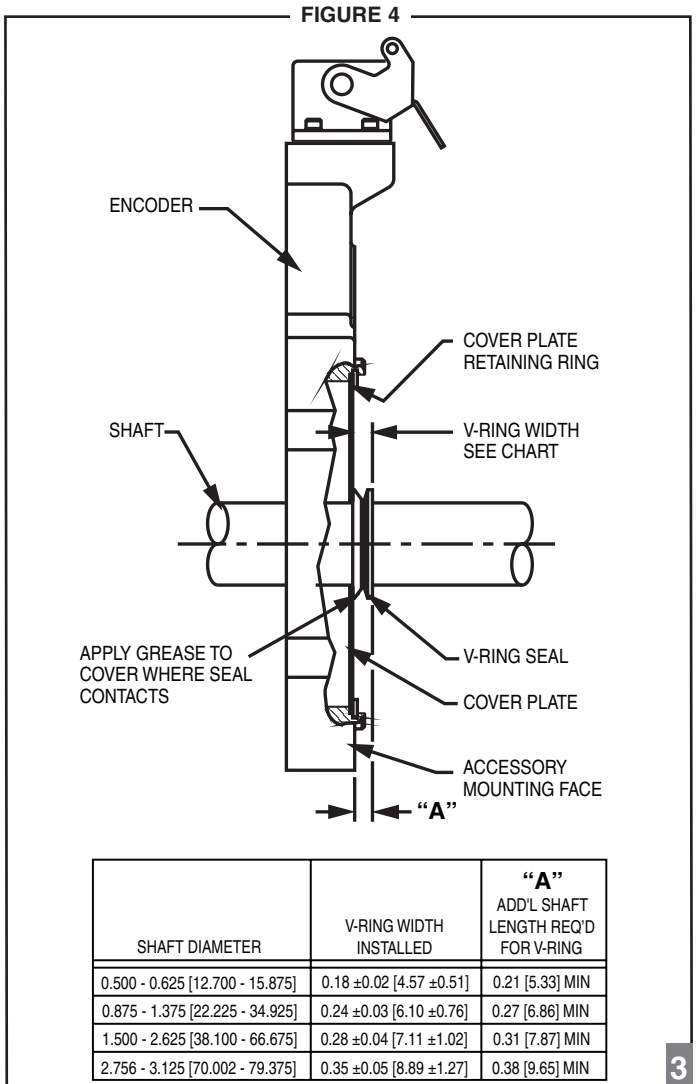

ring. Insert the cover, smooth side facing out, fully into the machined step until it seats against shoulder. Using a spiral assembly method, install the retaining ring by first inserting the squared off end into the machined groove. Flex the ring and insert it into the groove walking it around the perimeter (A flat blade screwdriver can be used). Final position should have the ring fully seated into groove. Remove the cover by reversing above procedure, starting with the tang end.

V-RING INSTALLATION FOR THRU SHAFT COVERS
(Cover Style option "T")

For thru shaft covers, verify that the shaft passes completely through the hole in the cover. Apply a small amount of silicone lubricant to the cover plate around the thru

shaft hole. The V-ring seal should compress axially when it is pressed against the clean, smooth face of the cover plate. See Figure 4 for proper installation and V-Ring compression.

CONNECTOR SPARE PARTS					
STYLE	OPTION CODE	ENCODER SIDE		CABLE SIDE PLUG	
Industrial EPIC on Encoder	P	315233	Base	315231	Hood
		315229	Terminal	315230	Terminal
Industrial EPIC w/ Adapter Block	Q			401112	Adapter
Industrial EPIC on 3' Cable	Z	315232	Surface	315231	Hood
		315229	Terminal	315230	Terminal
		471819	Bushing	401112	Adapter

END-of-SHAFT STYLE SPARE PARTS	
456050	Double FC Face Spacer
B29210	Shaft adapter use w/ 5/8" bore rotor, above

END-of-SHAFT STYLE SPARE PARTS							
SHAFT SIZE	OPTION CODE	ROTOR P/N				HARDWARE	SHAFT COVER
		128/256/512/1024/2048 PPR PPR OPTION A,B,C,D,E		120/240/480/600/960/1200 PPR PPR OPTION F,G,H,I,L,M			
		SET SCREW	CAM SCREW	SET SCREW	CAM SCREW		FLAT
1.1250/1.1245	W	B27564-1		B29231-1		#3/8-16 x 1.0" (1)	P/N B16999
2.1250/2.1245	X	B27564-2		B29231-2		#10-24 x 0.5" (2)	HARDWARE #10-24 x 0.5" (4)
2.3750/2.3745	Y	B27564-3		B29231-3		#3/8-16 x 0.88" (2)	
2.8750/2.8745	Z	B27564-4		B29231-4		#3/8-16 x 0.88" (2)	

THRU SHAFT SPARE PARTS								
SHAFT SIZE	OPTION CODE	ROTOR P/N				SHAFT COVERS		
		128/256/512/1024/2048 PPR PPR OPTION A,B,C,D,E		120/240/480/600/960/1200 PPR PPR OPTION F,G,H,I,L,M		THRU SHAFT	EXTENDED	FLAT
		SET SCREW	CAM SCREW	SET SCREW	CAM SCREW			
0.5000/0.4995	A	B27584-21	B30199-21	B29228-21	B30197-21	N/A	P/N A26777	P/N B16999
0.6250/0.6245	B	B27584-1	B30199-1	B29228-1	B30197-1	A28896-1	P/N A26777	P/N B16999
0.8750/0.8745	C	B27584-2	B30199-2	B29228-2	B30197-2	A28896-2		
0.9375/0.9370	D	B27584-3	B30199-3	B29228-3	B30197-3	A28896-3		
1.0000/0.9995	E	B27584-4	B30199-4	B29228-4	B30197-4	A28896-4		
1.1250/1.1245	F	B27584-5	B30199-5	B29228-5	B30197-5	A28896-5		
1.2500/1.2495	G	B27584-6	B30199-6	B29228-6	B30197-6	A28896-6		
1.3750/1.3745	H	B27584-7	B30199-7	B29228-7	B30197-7	A28896-7		
1.5000/1.4995	I	B27584-8	B30199-8	B29228-8	B30197-8	A28896-8		
1.6250/1.6245	J	B27584-9	B30199-9	B29228-9	B30197-9	A28896-9		
1.7500/1.7495	K	B27584-10	B30199-10	B29228-10	B30197-10	A28896-10		
1.8750/1.8745	L	B27584-11	B30199-11	B29228-11	B30197-11	A28896-11		
2.0000/1.9995	M	B27584-12	B30199-12	B29228-12	B30197-12	A28896-12		
2.1250/2.1245	N	B27584-13	B30199-13	B29228-13	B30197-13	A28896-13		
2.2500/2.2495	Q	B27584-14	B30199-14	B29228-14	B30197-14	A28896-14		
2.3750/2.3745	P	B27584-15	B30199-15	B29228-15	B30197-15	A28896-15		
2.5000/2.4995	R	B27584-16	B30199-16	B29228-16	B30197-16	A28896-16		
2.6250/2.6245	S	B27584-17	B30199-17	B29228-17	B30197-17	A28896-17		
2.7559/2.7554	T	B27584-18	B30199-18	B29228-18	B30197-18	A28896-18		
2.8750/2.8745	U	B27584-19	B30199-19	B29228-19	B30197-19	A28896-19		
3.0000/2.9995	V	B27584-20	N/A	B29228-20	N/A	A28896-20		
0.3937/0.3934	2	B27584-22	N/A	B29228-22	N/A	N/A		
0.4727/0.4723	3	B27584-23	N/A	B29228-23	N/A	N/A		
3.1250/3.1245	4	B30741-24	N/A	B30740-24	N/A	N/A		
3.3478/3.3469	6	B29530-15	N/A	B29329-15	N/A	N/A		
3.1875/3.1870	7	B30741-26	N/A	B30740-26	N/A	N/A		
HARDWARE		#8-32 x 0.19" (2)	N/A	#8-32 x 0.19" (2)	N/A	4.13" Ring 467368		

4 M85 through shaft length requirements: 0.63" long minimum, 0.93" long maximum for flat cover, and 2.75" long maximum for extended cover.

WIRING INSTRUCTIONS

CAUTION

Be sure to remove power before wiring the encoder.

Be sure to ground the cable shield: It can be connected to case ground at the encoder, or grounded at the receiving device, but should not be grounded on both ends.

Refer to the wiring diagrams for specific information on each option.

The M85 can be wired for single phase or two phase, either with or without complements, with or without markers. For bidirectional operation, Phase A channel leads phase B channel for clockwise shaft rotation as viewed from the anti-drive or accessory end of the motor (M85 mounting end).

NOTE

Avtron's convention for A and B wiring, as well as clockwise rotation, are EXACTLY REVERSED from Danaher Slimline™. This means the Avtron THIN-LINE M85 can be installed to an existing connection for Slimline SL85 and it will produce rotation in the expected direction without rewiring.

CORRECTIVE ACTION FOR PHASE REVERSAL

- 1) Remove Power.
- 2) Exchange wires on cable, either at encoder cable end, or at speed controller end (but not both).
 - a) **Single Ended 2 Phase Wiring** (see wiring diagram) Exchange A and B at the use end of the wires.
 - b) **Differential 2 Phase Wiring** (see wiring diagram) Exchange **either** A with \bar{A} in the phase A pair **OR** B with \bar{B} in the phase B pair but **NOT** both.
- 3) Apply Power.
- 4) Verify encoder feedback is correct, using hand rotation of shaft, or jog mode of the speed controller.

Interconnecting cables specified in the wire selection chart are based on typical applications. Physical properties of cable such as abrasion, temperature, tensile strength, solvents, etc., are dictated by the specific application. General electrical requirements are: stranded copper, 22 through 16 AWG (Industrial EPIC Connector type options can use 14 AWG), each wire pair individually shielded with braid or foil with drain wire, .05 uf of maximum total mutual or direct capacitance, outer sheath insulator. See specifications for maximum cable length. Stranded 22 AWG wire should not be used for cable runs greater than 200 feet. If 22 AWG is used with EPIC type connector options the wire ends should be tinned.

WIRING DIAGRAMS

FOR DIFFERENTIAL APPLICATIONS

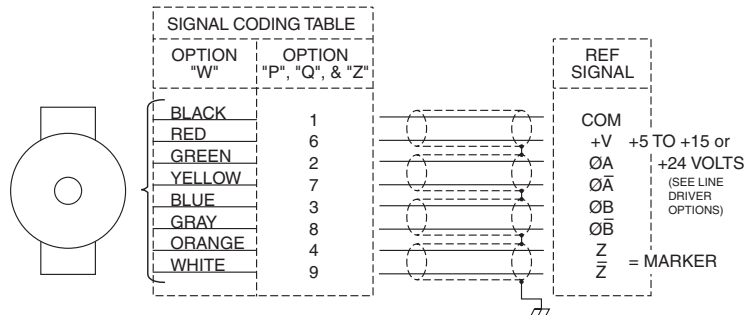

FOR SINGLE ENDED TWO PHASE APPLICATIONS

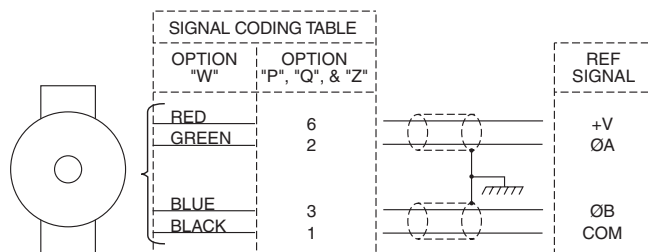

FOR SINGLE ENDED SINGLE PHASE APPLICATIONS

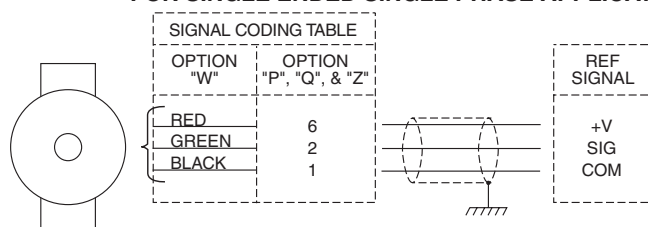

TYPICAL WIRE SELECTION CHART

for 18 AWG, multiple pair, individually shielded

	BELDEN	ALPHA
2 PAIR	9368	5620B1802
3 PAIR	9773 or 9369	6445
4 PAIR	9388	6444
3 CONDUCTOR	9365	5640B1801

For option "W", unused outputs must be insulated to prevent accidental contact.

NOTE: Avtron standard 3 year warranty applies. Copies available upon request. Specifications subject to change without notice.

OUTLINE DRAWING

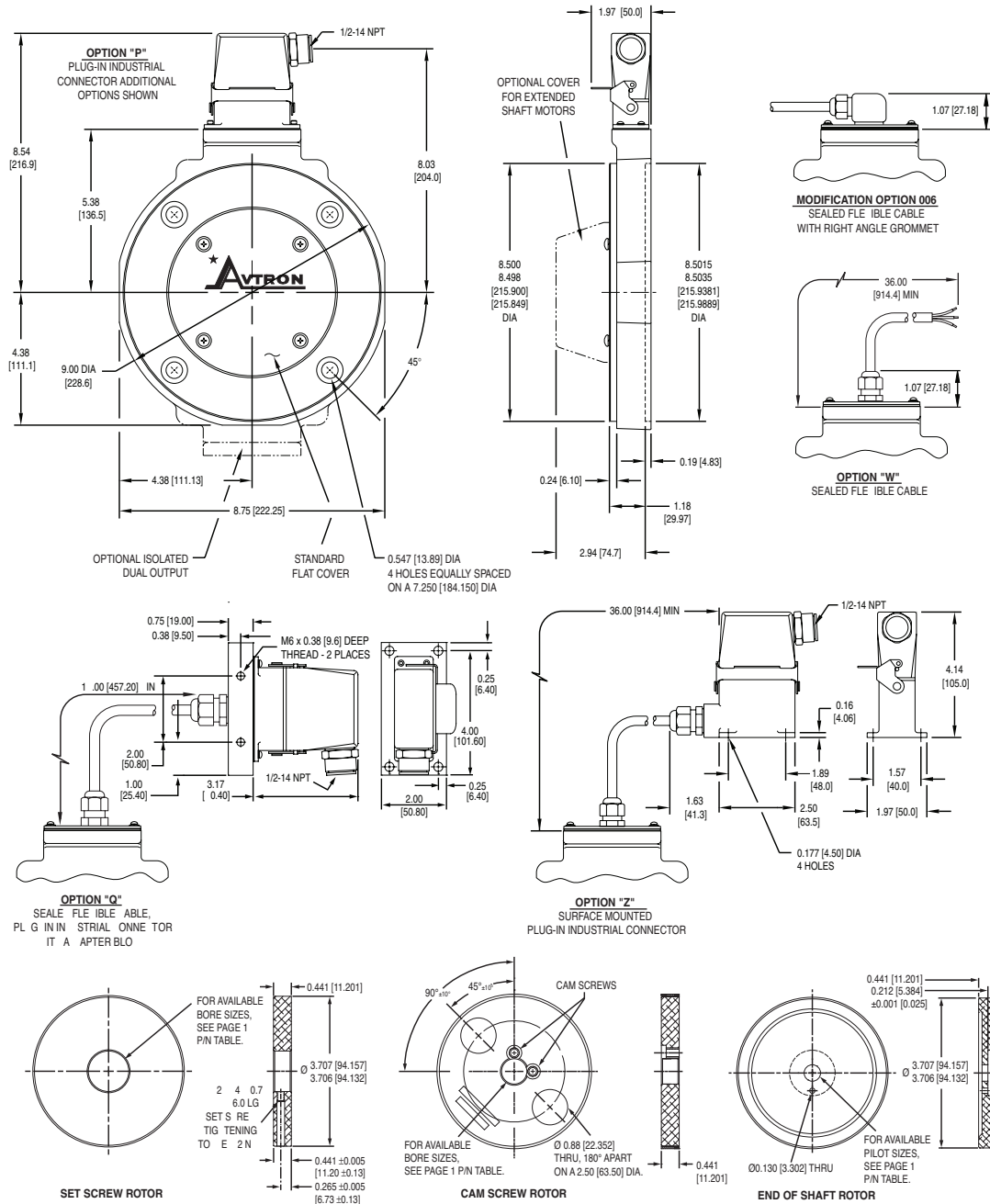

3 - DIMENSIONS IN INCHES [MILLIMETERS]
2 - ALL DIMENSIONS ARE APPROXIMATE
1 - WEIGHT: 2.5 TO 4 LBS. [1.13 TO 1.81 KG.]
NOTES:

EU DECLARATION OF CONFORMITY

The Model M85 Pulse Generator has been assessed and type tested against the following Harmonized European Standards: BS EN 61000-6-1: 2001, BS EN 61000-6-2: 2001, BS EN 61000-6-3: 2001, BS EN 61000-6-4: 2001. The Model M85 has been found to be compliant with the requirements of EU Directive 89/336/EEC as Amended by EU Directive 93/68/EEC "EMC Directive" provided the following conditions are met: The electrical supply to the M85 must be within specified limits. The electrical supply must offer suitable protection from voltage surges unless the application does not require such protection. On behalf of Avtron: Stephen L D'Henin, Certification Manager, Epsilon Certification Service.

Features and specifications subject to change without notice.
Avtron standard warranty applies. All dimensions are in inches [mm] approx.

