



AVTRON MANUFACTURING, INC.

8901 E. PLEASANT VALLEY ROAD
 INDEPENDENCE, OHIO 44131-5508
 TELEPHONE: (1) 216-642-4234 • FAX: (1) 216-642-9743
 E-MAIL: tachs@avtron.com • WEB: www.avtron.com/tachs.htm

**Pulse Generator
 Shaft Grounding
 Option Instructions**

KIT P/N A24491
 for use on
Model M3 & M4

DESCRIPTION

The shaft grounding factory installed option is designed for use with Avtron pulse generators for the reduction of bearing problems caused by shaft currents. For SLAPTach™ applications, kits are available for on-site customer installation.

Under certain operating conditions, a motor shaft can be subjected to shaft currents that seek the lowest resistance path through the pulse generator bearings. This can result in shortened bearing life.

The M3/M4 shaft grounding option provides a low resistance path to divert shaft currents away from the bearings. When the shaft grounding option is provided, it is an integral part of the pulse generator. NOTE: No additional changes to the motor shaft or added stub shafts are required.

The shaft grounding option consists of a gasket sealed brush holder, a brush, a wire lug, and stainless steel mounting hardware. These components are attached to the pulse generator anti-drive end plate with the brush contacting the pulse generator shaft. The wire lug provided is for simplified customer ground connection.

2. A ground wire (6 to 14 AWG) must be connected to the lug attached to the side of the brush holder. The ground wire should be connected to a good earth ground, typically the motor frame.

For pulse generator installation information refer to the instruction sheet provided with the pulse generator.

MAINTENANCE

WARNING

All maintenance procedures listed below must be performed by qualified personnel, and with the motor turned OFF to prevent possible injury or death of maintenance personnel.

Inspection

A new brush is 5/8" long. The brush should be replaced after it has worn 3/8" maximum (see Figure 2 - Shaft Grounding Option Disassembly). The brush should be inspected after 1 year to determine the wear rate for each installation. Replace brush if it is worn to a length of 1/4".

Cleaning

The brush holder cavity should be cleaned every time the brush is removed for inspection. Refer to Figure 2 - Shaft Grounding Option Disassembly, and clean as follows:

1. Remove the cap screw and brush.
2. Remove pipe plug from the bottom of the brush holder.

WARNING

Use safety goggles when using compressed air to prevent possible eye injuries.

3. Use dry compressed air applied through the brush opening to blow out any worn brush material residue through the bottom of the brush holder. An optional method is to suction the brush residue using a vacuum cleaner.

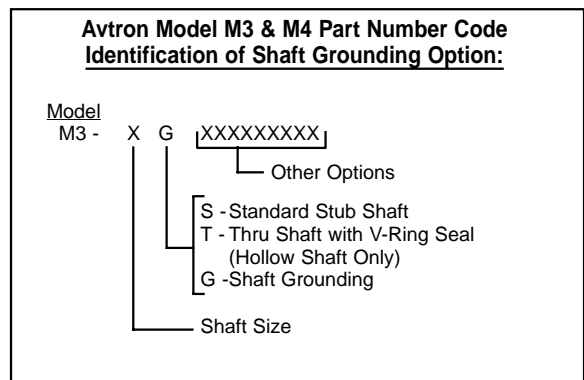

INSTALLATION

Installation of pulse generators equipped with the shaft grounding option is identical to non-grounded units except for two differences:

1. For brush service, an additional clearance is required from the anti-drive end plate of the pulse generator (see Figure 1 - Outline Drawing shown on next page.)

Shaft Grounding Option Replacement Parts List:

Part No.	Qty.	Description
410523	1	Brush
410522	1	Cap Screw, Brush Holder
416559	1	Pipe Plug
C23971	1	Brush Holder
367013	1	Terminal Lug

FIGURE 1 – Outline Drawing

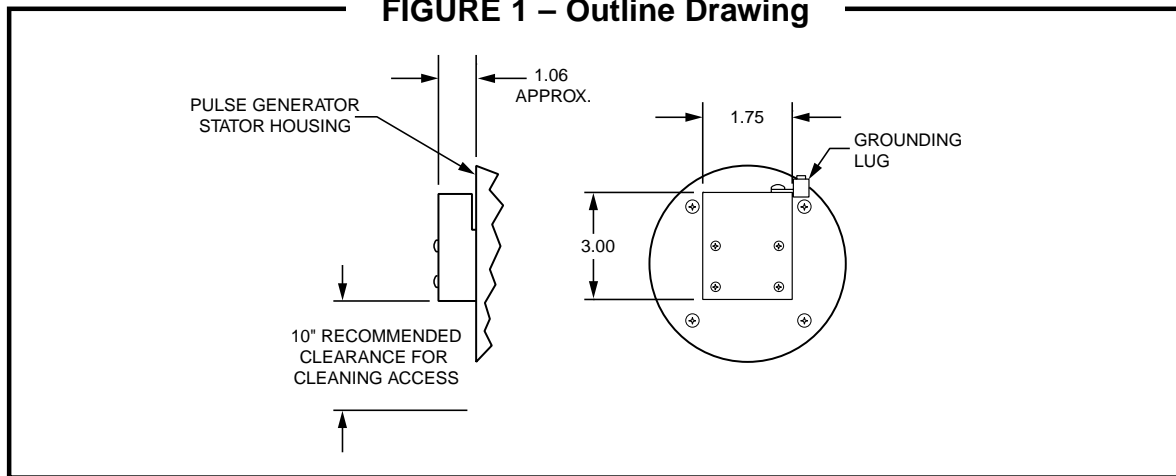
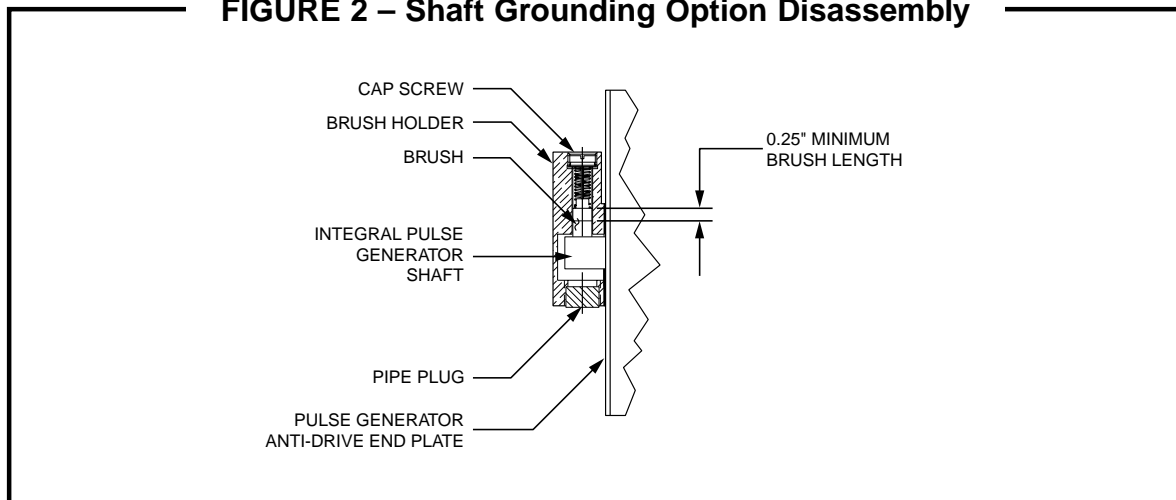

FIGURE 2 – Shaft Grounding Option Disassembly



Specifications subject to change without notice.
All dimensions are approximate.
Printed in the U.S.A. REV. 04-27-01