



6255 HALLE DRIVE, CLEVELAND, OH, U.S.A. 44125
(1) 216-573-7600 • FAX: (1) 216-573-5953

RESISTIVE LOAD BANK

150 AMPERE

MODEL K492



QUALITY SYSTEM CERTIFIED TO
ISO 9001

- **Flexible and Simple Operation**
- **Compact, Portable, Lightweight**
- **Easy to Read Meters**
- **Overtemperature Protected**
Removes loads if overheating occurs
- **No Cool Down Period Required**
- **Master Load Control Switch**
Allows for instant application or removal of loads

The Avtron Model K492 is a lightweight, DC resistive load bank contained in a small enclosure, providing up to 150 amperes loading capacity for testing UPS and other DC power sources at either 26 or 52 volts DC.

Avtron designed and manufactured, the K492 resistive load elements are at the core of the load bank system. To ensure years of reliable operation, the elements chosen for the K492 will operate at only 1/3 (or less) of their maximum temperature rating. The load bank includes overtemperature protection and does not require a "cool down" period after each use.

The K492 is simple to use. It does not require tools or a separate source for control power. Electrical connections are made on the front of the unit using hand-tightened terminals, while control power is derived from the power source being tested. A large, easy to read voltmeter (0-60 V, $\pm 2\%$) and ammeter (0-200 A, $\pm 2\%$), along with logically arranged controls, make this load bank a snap to use.

The K492 is intended to be an essential piece of test equipment used by field service personnel. Its reliable and simple-to-operate design, compact frame size, comfortable carrying handle, and light weight define this unit as the "load bank of choice."

The Avtron K492 is designed for testing batteries and DC power sources most commonly used in the telecommunications industry.

Avtron's extensive line of Load Bank and Industrial Resistor Products are solid performers used throughout the world.

For total technical support or additional information, please contact Avtron at (216) 573-7600 or LBsales@avtron.com.

K492 LOAD CAPACITY RATINGS

| Total Load Amps | Voltage | Load Steps in Amps | | | | | | | | | | Part # | | |
|-----------------|---------|--------------------|---|---|---|----|----|----|----|----|----|--------|----|--------|
| | | 1 | 2 | 2 | 5 | 10 | 10 | 20 | 20 | 20 | 20 | | 20 | |
| 150 | 26/52 | 1 | 2 | 2 | 5 | 10 | 10 | 20 | 20 | 20 | 20 | 20 | 20 | D25723 |

Other Voltages and capacities available.

K492 SPECIFICATIONS

CAPACITY: Up to 150 Amps DC.

LOAD STEP RESOLUTION: 1 Amp.

VOLTAGE: 26 or 52 volts.

BLOWER POWER: Taken from load bus.

CONTROL POWER: Taken from load bus.

CONTROLS AND INDICATORS:

- Master Load ON/OFF
- 12 Load Step Switches, toggle type
- Overtemperature Indicator

LOAD ELEMENTS:

- Avtron helically wound chromium alloy wire
- No "cool down" required
- Overtemperature protected

CONSTRUCTION:

- Durable steel enclosure protected with powder coat paint finish.
- Rubber support feet
- Large, comfortable carrying handle
- Designed for indoor use
- Cooling Fans: 4 muffin type, for quiet operation and low power usage of approximately 1.9 Amps at 26/52 VDC

WEIGHT: Approximately 30 pounds

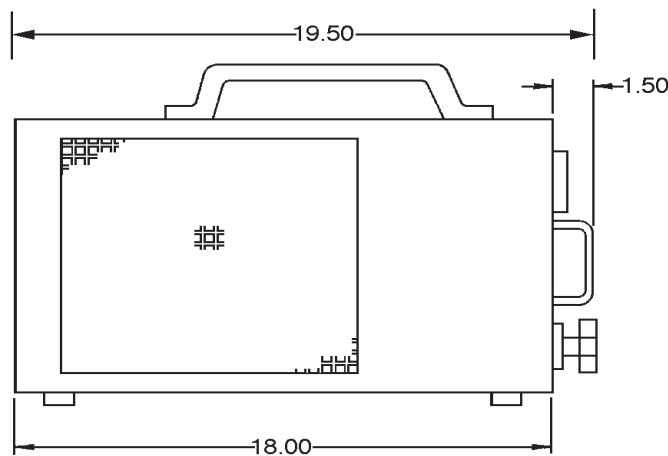

EXHAUST SIDE

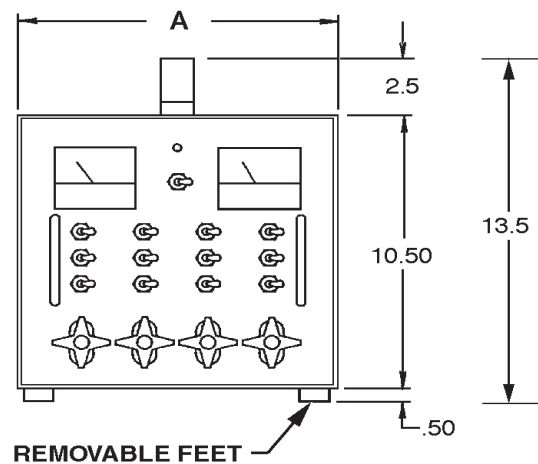

REMOVABLE FEET

All dimensions are in inches.
 Specifications subject to change without notice.
 Printed in U.S.A. Rev. C

