

**AVTRON MODEL LPS
OUTDOOR SKID MOUNTED LOAD BANK SYSTEM
OUTLINE DRAWING SET**

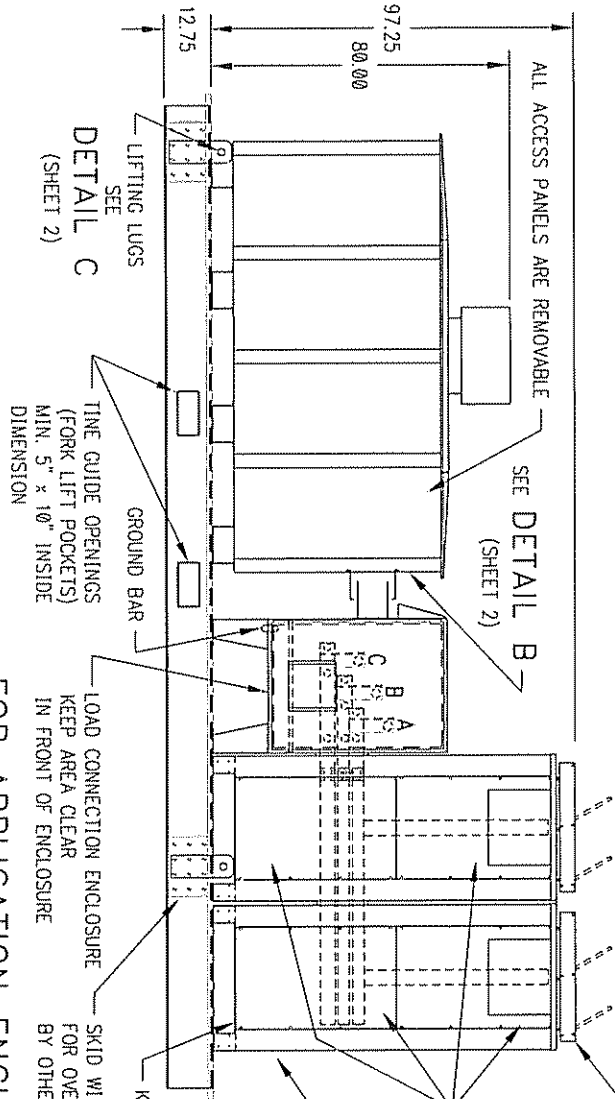
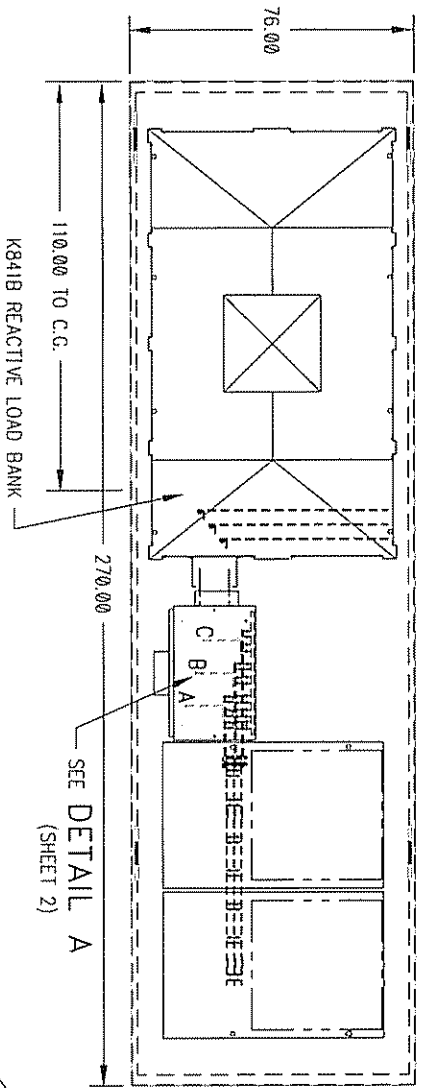

BOLT ON STAINLESS STEEL GRAVITY EXHAUST HATCHES. HIDDEN LINES INDICATE OPEN POSITION OF TOP PANELS (TWO PANELS PER STACK) DO NOT OBSTRUCT

REMOVABLE ACCESS PANELS, CLEARANCE REQUIRED TO REMOVE PANELS TO SERVICE UNIT.

DO NOT BLOCK LOWER 24" OF SIDES AND BACK OF RESISTIVE LOAD BANK. THESE AREAS ARE FOR INTAKE AIR. 40,000 CFM REQUIRED.

FOR APPLICATION ENGINEERING USAGE ONLY

7. DO NOT MODIFY SKID OR EQUIPMENT WITHOUT WRITTEN APPROVAL FROM AVTRON MFG. INC. AS SHOWN.
6. PARCELS OF RESISTIVE EXHAUST AIR WILL REACH 5000F OVER AMBIENT. MAXIMUM INTAKE AIR TEMPERATURE IS 120F. SEE MANUAL FOR DETAILED INSTALLATION & SITE CONDITIONS.
5. PROVIDE AN OPEN & CLEAR VERTICAL EXHAUST FIELD ABOVE THE RESISTIVE LOAD BANK FOR HEATED AIR. SEE MANUAL.
4. OVERHEAD LIFT STRUCTURE PROVIDED BY OTHERS. SEE SB3600 FOR OVERHEAD LIFT.
3. AS A GENERAL GUIDE, THE MINIMUM CLEARANCE REQUIRED FROM ANY OBSTRUCTION IS SIX FEET.
2. ALL DIMENSIONS ARE APPROX.
1. WEIGHT: 15,000 LBS

THIS DOCUMENT CONTAINS PROPRIETARY INFORMATION OF AVTRON MFG. INC. AND MAY NOT BE DISCLOSED TO OTHERS OR USED FOR MANUFACTURING PURPOSES WITHOUT THE WRITTEN CONSENT OF AVTRON MFG.

DESIGN	JFL/AUTO	DATE	1-16-07
CHECKED	JFL/AUTO	DATE	1-17-07
APPROVED	JEMERY	SCALE	1/32
DESIGN	JFL/AUTO	DATE	1-16-07
CHECKED	JFL/AUTO	DATE	1-17-07
APPROVED	JEMERY	SCALE	1/32

AVTRON MANUFACTURING, INC.
 10000 W. 10TH AVENUE, SUITE 100
 DENVER, CO 80231
 TEL: 303.751.1000 FAX: 303.751.1001
 WWW.AVTRONMFG.COM

LOAD BANK SYSTEM,
 SKID MOUNTED

DRIVING NUMBER
 SB3817
 SH1 OF 2
 OUTLINE DRAWING

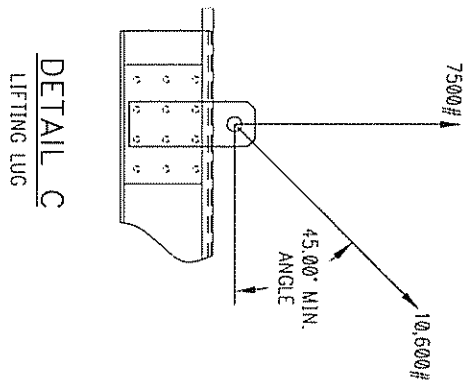
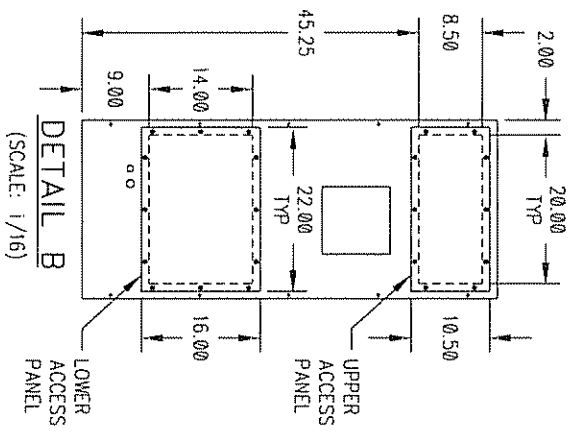
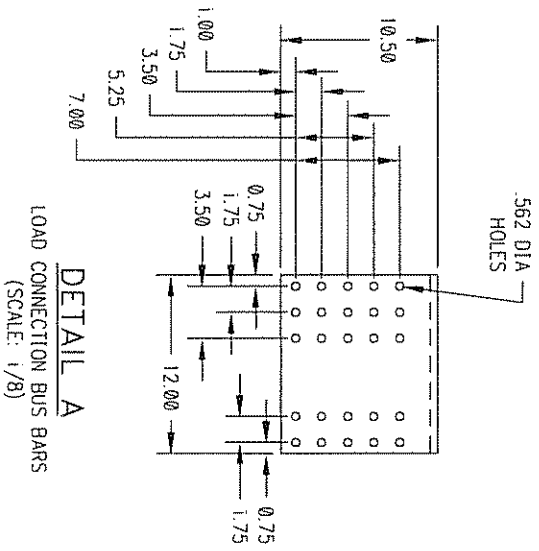

LOADS SHOWN PER LUG ARE NOT CUMULATIVE.
 MAXIMUM APPLIED LOADS CAN BE 7,500 LBS.
 VERTICAL OR 10,600 LBS. @ 45° , NOT BOTH.

FOR APPLICATION ENGINEERING USAGE ONLY

NO.	REV	DATE	BY	CHK'D
1	A	5/2/07	JENERY	CHKO
REVISION: A: REVISION SHEET FOR DETAILS RANER				
CHANGE				

THIS DOCUMENT CONTAINS PROPRIETARY INFORMATION OF AVTRON MFG., INC. AND MAY NOT BE DISCLOSED TO OTHERS OR USED FOR MANUFACTURING PURPOSES WITHOUT THE WRITTEN CONSENT OF AVTRON MFG.

AVTRON MANUFACTURING, INC.
 INDEPENDENCE, OH
 LOAD BANK SYSTEM,
 SKID MOUNTED

DRAWING NUMBER: SB3817
 SHEET: SH1 2
 OUTLINE DRAWING

NOTES: